



# LS 400Xi

*About This Manual*

*Table Of Contents*

*Index*

*Copyright*

*Feedback*



## Product Reference Guide

70-33848-01

Revision A

August 1998



© 1998 by Symbol Technologies, Inc. All rights reserved.

No part of this publication may be reproduced or used in any form, or by any electrical or mechanical means, without permission in writing from Symbol. This includes electronic or mechanical means, such as photocopying, recording, or information storage and retrieval systems. The material in this manual is subject to change without notice.

The software is provided strictly on an “as is” basis. All software, including firmware, furnished to the user is on a licensed basis. Symbol grants to the user a non-transferable and non-exclusive license to use each software or firmware program delivered hereunder (licensed program). Except as noted below, such license may not be assigned, sublicensed, or otherwise transferred by the user without prior written consent of Symbol. No right to copy a licensed program in whole or in part is granted, except as permitted under copyright law. The user shall not modify, merge, or incorporate any form or portion of a licensed program with other program material, create a derivative work from a licensed program, or use a licensed program in a network without written permission from Symbol. The user agrees to maintain Symbol’s copyright notice on the licensed programs delivered hereunder, and to include the same on any authorized copies it makes, in whole or in part. The user agrees not to decompile, disassemble, decode, or reverse engineer any licensed program delivered to the user or any portion thereof.

Symbol reserves the right to make changes to any software or product to improve reliability, function, or design.

Symbol does not assume any product liability arising out of, or in connection with, the application or use of any product, circuit, or application described herein.

No license is granted, either expressly or by implication, estoppel, or otherwise under any Symbol Technologies, Inc., intellectual property rights. An implied license only exists for equipment, circuits, and subsystems contained in Symbol products.

Symbol, Spectrum One, and Spectrum24 are registered trademarks of Symbol Technologies, Inc. Other product names mentioned in this manual may be trademarks or registered trademarks of their respective companies and are hereby acknowledged.

Symbol Technologies, Inc.  
One Symbol Plaza  
Holtsville, New York 11742-1300  
<http://www.symbol.com>

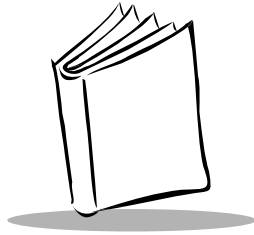

# Contents

## About This Manual

Notational Conventions . . . . .	i
Related Publications . . . . .	i
Service Information . . . . .	i
Symbol Support Center . . . . .	ii

## Chapter 1. The LS 400Xi Scanner

Scanning Made Easy . . . . .	1-1
------------------------------	-----

## Chapter 2. Set Up

Unpacking . . . . .	2-1
Cables . . . . .	2-1
Installing the Cable . . . . .	2-1
Switching Cables . . . . .	2-3
Power Options . . . . .	2-3
Battery Box Operation . . . . .	2-4
Changing the Battery . . . . .	2-4
Recharging a Nickel-Cadmium Battery . . . . .	2-4
Connecting to a Host - 1D Scanning . . . . .	2-5
RS-232C (LS 4004i) . . . . .	2-5
Keyboard Wedge . . . . .	2-7
IBM 468X/9X (LS 4005i) . . . . .	2-8
Connection to a Host - PDF Scanning . . . . .	2-11

## Chapter 3. Scanning

Scanning 1-D Bar Codes . . . . .	3-1
Aiming . . . . .	3-2
Scan the Entire Symbol . . . . .	3-2

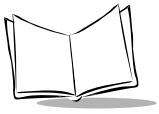

Hold at an Angle . . . . . 3-2

Scanning PDF417 (2-D) Bar Codes . . . . . 3-3

What If... . . . . 3-4

    Nothing happens when you follow the operating instructions? . . . . . 3-4

    Symbol is decoded, but not transmitted to the host terminal? . . . . . 3-4

    Scanned data is incorrectly displayed on the terminal? . . . . . 3-4

## Chapter 4. Maintenance & Specifications

Maintenance . . . . . 4-1

Accessories. . . . . 4-1

    Required Accessories . . . . . 4-1

    Optional Accessories . . . . . 4-1

Technical Specifications. . . . . 4-2

LS 400Xi 1-D Decode Zone. . . . . 4-4

LS 400Xi 2-D Decode Zone. . . . . 4-5

Pin-outs . . . . . 4-6

Beeper Indications . . . . . 4-7

## Chapter 5. Parameter Menus

Operational Parameters . . . . . 5-1

Set Default Parameter . . . . . 5-7

Host Type . . . . . 5-8

    IBM 46XX Host Types. . . . . 5-8

    RS-232C Host Types . . . . . 5-9

Beeper Tone. . . . . 5-12

Beeper Volume. . . . . 5-13

Laser On Time. . . . . 5-14

Power Mode . . . . . 5-15

Beep After Good Decode . . . . . 5-16

Transmit “No Read” Message. . . . . 5-17

PDF Decode Feedback . . . . . 5-18

Linear Code Type Security Level . . . . . 5-19

    Linear Security Level 1 . . . . . 5-19

    Linear Security Level 2 . . . . . 5-19

    Linear Security Level 3 . . . . . 5-20

    Linear Security Level 4 . . . . . 5-20

Bi-directional Redundancy. . . . . 5-21

Enable/Disable UPC-E/UPC-A/UPC-E1 . . . . . 5-22

Enable/Disable EAN-8/EAN-13. . . . . 5-23

Enable/Disable Bookland EAN . . . . . 5-24

Decode UPC/EAN Supplementals . . . . . 5-25

Decode UPC/EAN Supplemental Redundancy . . . . . 5-26

Transmit UPC-A/UPC-E/UPC-E1 Check Digit .....	5-27
UPC-A Preamble .....	5-28
UPC-E Preamble .....	5-29
UPC-E1 Preamble .....	5-30
Convert UPC-E to UPC-A .....	5-31
Convert UPC-E1 to UPC-A .....	5-32
EAN Zero Extend .....	5-33
Convert EAN-8 to EAN-13 Type .....	5-34
UPC/EAN Security Level .....	5-35
UPC/EAN Security Level 0 .....	5-35
UPC/EAN Security Level 1 .....	5-35
UPC/EAN Security Level 2 .....	5-36
UPC/EAN Security Level 3 .....	5-36
UPC/EAN Coupon Code .....	5-37
Enable/Disable Code 128 .....	5-38
Enable/Disable UCC/EAN-128 .....	5-39
Lengths for Code 128 .....	5-39
Enable/Disable Code 39 .....	5-40
Enable/Disable Trioptic Code 39 .....	5-41
Convert Code 39 to Code 32 .....	5-42
Code 32 Prefix .....	5-43
Set Lengths for Code 39 .....	5-44
Code 39 Check Digit Verification .....	5-46
Transmit Code 39 Check Digit .....	5-47
Enable/Disable Code 39 Full ASCII .....	5-48
Code 39 Buffering (Scan & Store) .....	5-49
Buffer Data .....	5-50
Clear Transmission Buffer .....	5-50
Transmit Buffer .....	5-51
Overfilling Transmission Buffer .....	5-51
Attempt to Transmit an Empty Buffer .....	5-51
Enable/Disable Code 93 .....	5-52
Set Lengths for Code 93 .....	5-53
Enable/Disable Interleaved 2 of 5 .....	5-55
Set Lengths for Interleaved 2 of 5 .....	5-56
I 2 of 5 Check Digit Verification .....	5-58
Transmit I 2 of 5 Check Digit .....	5-59
Convert I 2 of 5 to EAN-13 .....	5-60
Enable/Disable Discrete 2 of 5 .....	5-61
Set Lengths for Discrete 2 of 5 .....	5-62
Enable/Disable Codabar .....	5-64
Set Lengths for Codabar .....	5-65
CLSI Editing .....	5-67
NOTIS Editing .....	5-68

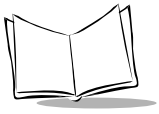

Enable/Disable MSI Plessey . . . . .	5-69
Set Lengths for MSI Plessey . . . . .	5-70
MSI Plessey Check Digits . . . . .	5-72
Transmit MSI Plessey Check Digit . . . . .	5-73
MSI Plessey Check Digit Algorithm . . . . .	5-74
Enable/Disable PDF417 . . . . .	5-75
Transmit Code ID Character . . . . .	5-76
Symbol Code ID Characters . . . . .	5-76
Pause Duration . . . . .	5-78
Prefix/Suffix Values . . . . .	5-79
Scan Data Transmission Format . . . . .	5-80
RS-232C Parameters . . . . .	5-82
Baud Rate . . . . .	5-82
Parity . . . . .	5-84
Check Receive Errors . . . . .	5-85
Hardware Handshaking . . . . .	5-86
Software Handshaking . . . . .	5-88
Host Serial Response Time-out . . . . .	5-90
RTS Line State . . . . .	5-90
Stop Bit Select . . . . .	5-91
ASCII Format . . . . .	5-91
Beep on <BEL> . . . . .	5-92
Intercharacter Delay . . . . .	5-92
Numeric Bar Codes . . . . .	5-93
Cancel . . . . .	5-95

## Appendix A. Programming Reference

UCC/EAN-128 . . . . .	A-1
AIM Code Identifiers . . . . .	A-3

## Index

## Feedback

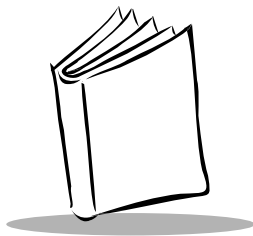

## About This Manual

The *LS 400Xi Product Reference Guide* provides general instructions for setup, operation, troubleshooting, maintenance, and programming of the LS 400Xi scanner.

### Notational Conventions

---

The following conventions are used in this document:

- ◆ LS 400Xi refers to both the LS 4004i and the LS 4005i, unless specifically noted.
- ◆ Bullets (•) indicate:
  - ◆ action items
  - ◆ lists of alternatives
  - ◆ lists of required steps that are not necessarily sequential
- ◆ Sequential lists (e.g., those that describe step-by-step procedures) appear as numbered lists.
- ◆ References to other sections, chapters, or manuals appear in italics.

### Related Publications

---

- ◆ *LS 400Xi Quick Reference Guide* p/n 70-33849-xx

### Service Information

---

If you have a problem with your equipment, contact the Symbol Support Center. Before calling, have the model number, serial number, and several of your bar code symbols at hand.

Call the Support Center from a phone near the scanning equipment so that the service person can try to talk you through your problem. If the equipment is found to be working properly

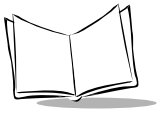

and the problem is symbol readability, the Support Center will request samples of your bar codes for analysis at our plant.

If your problem cannot be solved over the phone, you may need to return your equipment for servicing. If that is necessary, you will be given specific directions.

---

**Note:** *Symbol Technologies is not responsible for any damages incurred during shipment if the approved shipping container is not used. Shipping the units improperly can possibly void the warranty. If the original shipping container was not kept, contact Symbol to have another sent to you.*

---

## Symbol Support Center

---

For service information, warranty information or technical assistance contact or call the Symbol Support Center in:

### United States

Symbol Technologies, Inc.  
One Symbol Plaza  
Holtsville, NY 11742-1300  
1-800-653-5350

### Canada

Symbol Technologies Canada, Inc.  
2540 Matheson Boulevard East  
Mississauga, Ontario, Canada L4W 4Z2  
(905) 629-7226

### International

Symbol Technologies International  
Symbol Place  
Winnersh Triangle, Berkshire RG41 5TP UK  
United Kingdom  
0800 3282424 (Inside UK)  
+44 118 945 7529 (Outside UK)

### Asia/Pacific

Symbol Technologies Asia, Inc.  
230 Victoria Street #04-05  
Bugis Junction Office Tower  
Singapore 188024  
337-6588 (Inside Singapore)  
+65-337-6588 (Outside Singapore)

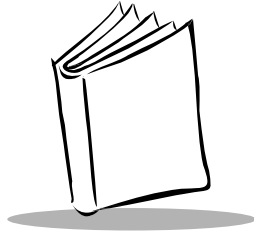

## *Chapter 1*

# *The LS 400Xi Scanner*

### **Scanning Made Easy**

---

Symbol Technologies, the world leader in hand-held laser scanning, now offers 21st century technology while maintaining compatibility with today's existing systems. The LS 400Xi hand-held laser scanner offers the best performance in retail and light industrial applications. Advanced ergonomic design ensures comfortable use for extended periods of time.

The LS 400Xi hand-held laser scanner offers the best performance in retail and light industrial applications. It uses a 650nm laser diode for improved scan line visibility, and has a scan rate of approximately 100 scans/second. These factors make the LS 400Xi even more aggressive than ever on 1-D bar codes, and also offer the added dimension of entry level PDF scanning.

The LS 400Xi is intended for applications where 1-D scanning is a priority, with an occasional need to scan PDF symbols. The product is ideal for applications such as point-of-sale where the majority of scanning is items with UPC or EAN/JAN bar codes, with an occasional scan of a PDF symbol on a courtesy card, a coupon, etc.

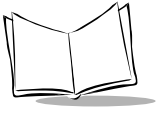

Here's what the LS 400Xi offers you:

- ◆ **The LS 4004i (RS-232C)** - This scanner contains onboard discrete RS-232C communications for connecting to RS-232C asynchronous terminals and host systems. It also accommodates any of the Synapse™ “Smart Cables” which allows you to connect to a wide variety of host systems.
- ◆ **The LS 4005i (IBM 468X/469X)** - This scanner is fully compatible with the entire line of IBM 468X/469X terminals. It also accommodates the full line of Synapse Smart Cables.

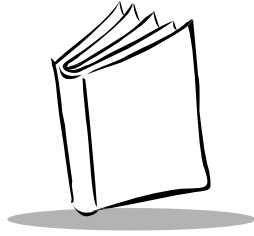

## *Chapter 2*

### *Set Up*

## **Unpacking**

---

Remove the scanner from its packing and inspect it for damage. If the scanner was damaged in transit, call the [Symbol Support Center](#) at one of the telephone numbers listed on [page ii](#). **KEEP THE PACKING.** It is the approved shipping container and should be used if you ever need to return your equipment for servicing.

## **Cables**

---

### ***Installing the Cable***

1. Switch off all devices connected to the LS 400Xi.

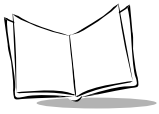

2. Pull the boot up over the cable until just the connector is protruding ([Figure 2-1](#)).

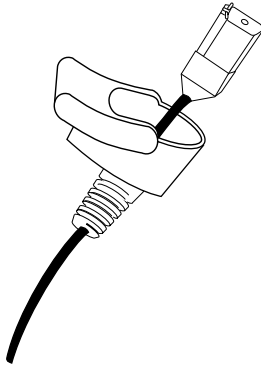

Figure 2-1. Scanner Cable

3. Plug the modular connector on the cable into the receptacle in the bottom of the LS 400Xi handle ([Figure 2-2](#)). Listen for a click.

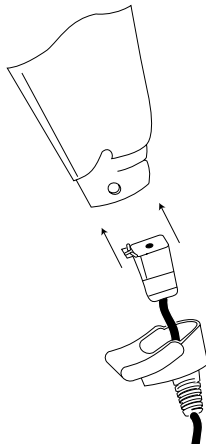

Figure 2-2. Plugging in the Modular Connector

4. Gently tug the cable to ensure the connector is properly secured.

5. Slide the boot up while observing its orientation until it is securely in place ([Figure 2-3](#)).

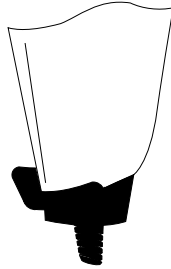

Figure 2-3. Boot Securely in Place

6. Make certain the semi-circular key on the boot slides inside the handle assembly, and that the boot snaps into place.
7. Gently pull the boot to be sure it is properly seated.

## Switching Cables

Different cables are required for different hosts. To change the scanner cable:

1. Slide the boot down over the cable.
2. Unplug the modular connector by depressing the connector clip (through the access hole), and remove existing cable.
3. Follow steps for [Installing the Cable on page 2-1](#).

## Power Options

---

Three power options are available:

- ◆ External power supply
- ◆ Battery box
- ◆ Direct host power (IBM Series - LS 4005i only)

Available power options are host dependent.

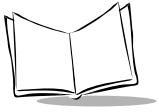

## Battery Box Operation

---

When using the LS 400Xi with a battery box, you can use either an alkaline battery (recommended), or a nickel-cadmium rechargeable battery.

### ***Changing the Battery***

1. To open the battery box, push up on the flanges at one end of the pack.
2. Remove the old battery.
3. Insert the new or recharged 9-volt battery into the battery box. Match the positive (+) and negative (-) terminals on the battery with the corresponding terminals in the battery box.

### ***Recharging a Nickel-Cadmium Battery***

Remove the battery from the battery box and place it in the recharging unit (not supplied by Symbol).

To recharge the battery, follow the instructions supplied with the recharging unit.

## Connecting to a Host - 1D Scanning

---

With some terminal types, the LS 400Xi is unable to answer host terminal polls until the appropriate host type is selected. If the appropriate host type is not selected, the connected host may generate an error message. To correct this situation, select the proper parameter set and initialize the host terminal. See [Chapter 5](#) for more information.

### RS-232C (LS 4004i)

#### Direct RS-232

For direct RS-232 connection, plug the LS 4004i interface cable directly into the scanner port on the back of the host. If necessary, connect a power supply to the host.

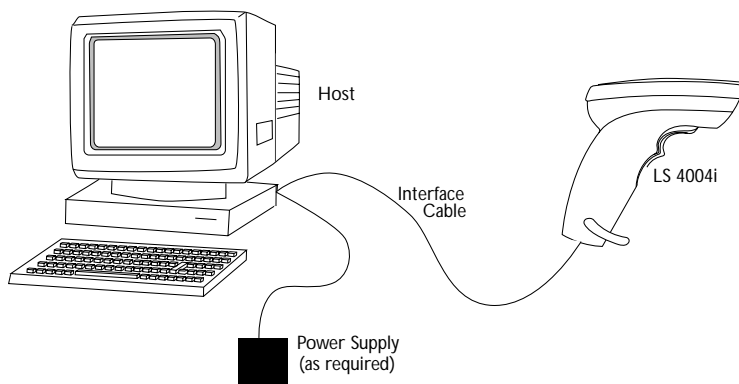
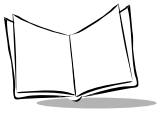

Figure 2-4. Direct RS-232 Configuration



## RS-232 via Synapse

To set up your RS-232 system via Synapse:

1. Connect the Synapse Smart Cable to the host.
2. Connect the Synapse Adapter cable to the Synapse cable, and the other end to the scanner.
3. If necessary, plug a power supply into the power port on the Synapse cable.

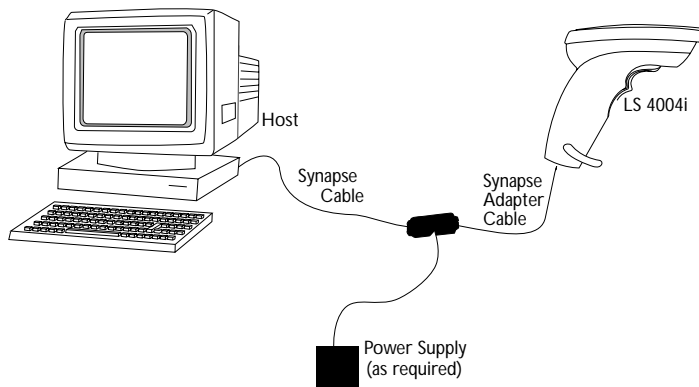

Figure 2-5. RS-232 via Synapse Configuration

## External Power Operation with Single-Piece Cable

1. Plug the scanner into the appropriate port on the host device.
2. Connect the power supply to the power port on the cable. Depending upon the cable being used, this is located on a “lump” on the cable or the cable’s host connector.

## Battery Operation

1. Insert a 9-volt battery into the battery box. Refer to [Battery Box Operation on page 2-4](#).
2. Plug the 9-pin connector at the end of the scanner’s coil cord into one end of the battery box.

3. An output cable from the battery box connects the LS 4004i to the RS-232C input device. Connect one end of this cable to the battery box and the other end to the appropriate port on the host device (Figure 2-6).

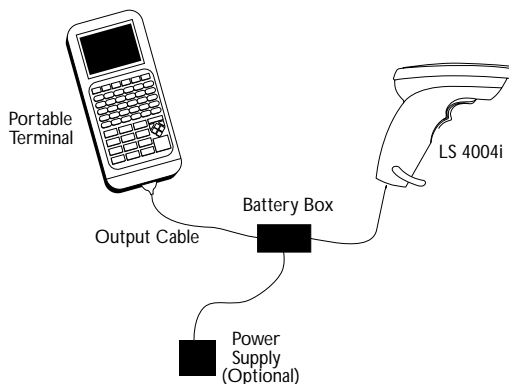

Figure 2-6. RS-232C Battery Operation

---

**Note:** *Coil cables that terminate in a 25-pin D-type connector have a power receptacle on the side of the connector assembly.*

---

## Keyboard Wedge

To setup the keyboard wedge configuration:

1. Connect the keyboard connector on the Synapse cable to the host keyboard.
2. Connect the host connector on the Synapse cable to the keyboard interface port on the host.
3. Connect the Synapse scanner connector to the scanner.

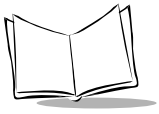

4. If necessary, plug a power supply into the power port on the Synapse cable.

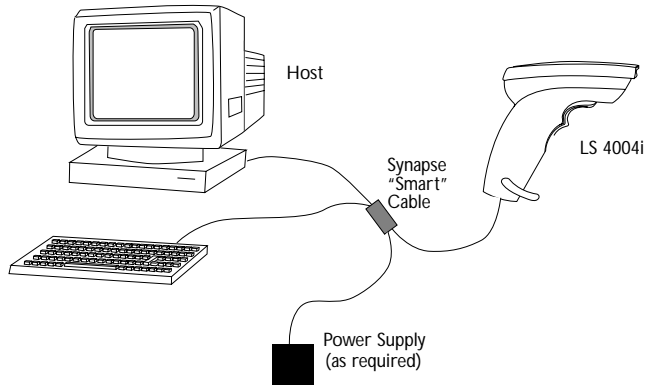

Figure 2-7. Keyboard Wedge Configuration

### IBM 468X/9X (LS 4005i)

Plug the SDL modular connector at the end of the selected scanner cable into the appropriate port (5, 5B, 9B, 9C, 9E, or 17). Check that the connection is secure. No additional power connections are necessary. Figures 2-9 through 2-12 show the rear of the IBM terminals with the covers removed. Note that the unit may be connected to one hardware port, and configured for a different software port using the bar codes in [IBM 46XX Host Types on page 5-8](#). The hardware ports available determine how the unit is connected to the host, while the software port configuration determines how it communicates.

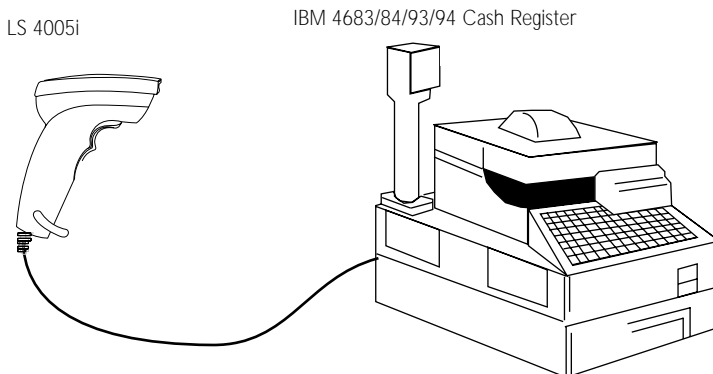
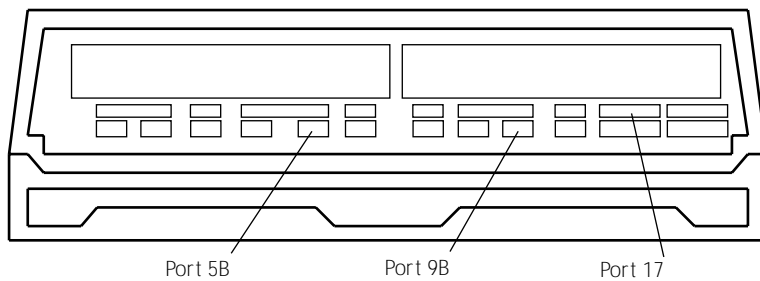
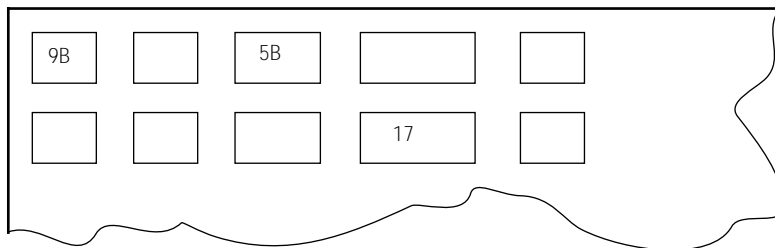

Figure 2-8. Typical System Configuration



**Figure 2-9. IBM 4683 Rear Panel With Cover Removed**



**Figure 2-10. IBM 4684 Rear Panel With Cover Removed**

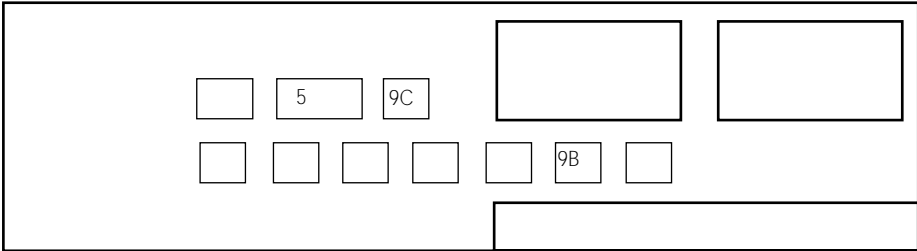
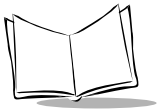

Figure 2-11. IBM 4693 Rear Panel With Cover Removed

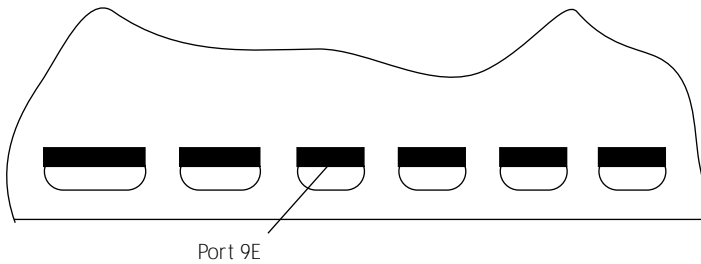

Figure 2-12. IBM 4694 Rear Panel With Cover Removed

## Connection to a Host - PDF Scanning

---

Currently, PDF417 can only be interfaced with the following host types:

- ◆ Direct RS-232 (refer to page [2-5](#))
- ◆ RS-232 via Synapse (refer to page [2-6](#))
- ◆ Keyboard Wedge (refer to page [2-7](#)).

The RS-232 Host Types that support PDF417 are:

- ◆ Standard RS-232C
- ◆ PDT 330

Refer to [Host Type on page 5-8](#) for more information.

---

**Note:** *PDF417 is not enabled by default. Scan the parameter bar code [ENABLE PDF417 on page 5-75](#) to enable PDF417 scanning capabilities.*

---

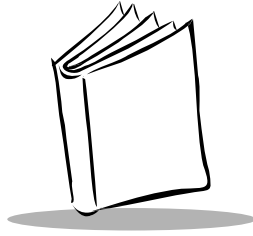

## Chapter 3 Scanning

### Scanning 1-D Bar Codes

---

To scan a 1-D bar code:

1. Make sure all connections are secure, and the symbol you want to scan is within the scanning range (refer to [Technical Specifications on page 4-2](#)).
2. Aim the scanner at the symbol and press the trigger. The scanning beam remains on for approximately 3.0 seconds (default) or until a successful decode.

The scanner has read the symbol when:

- ◆ You hear a short, high tone beep (if the beeper is enabled).
- ◆ The yellow LED on the rear of the scanner turns green.

The green LED stays lit for two seconds or until the next trigger pull.

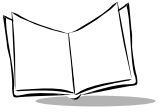

## Aiming

### Scan the Entire Symbol

- ◆ Cross every bar and space of the symbol with the scan beam.
- ◆ Hold the scanner further away for larger bar codes.
- ◆ Hold the scanner closer for symbols with bars that are close together.



### Hold at an Angle

Do not hold the scanner directly over the bar code. Laser light reflecting *directly* back into the scanner from the bar code is known as specular reflection. This strong light can “blind” the scanner and make decoding difficult. The area where specular reflection occurs is known as a “dead zone.”

You can tilt the scanner up to 65° forward or back and still achieve a successful decode (Figure 3-1.) Simple practice quickly shows what tolerances to work within.

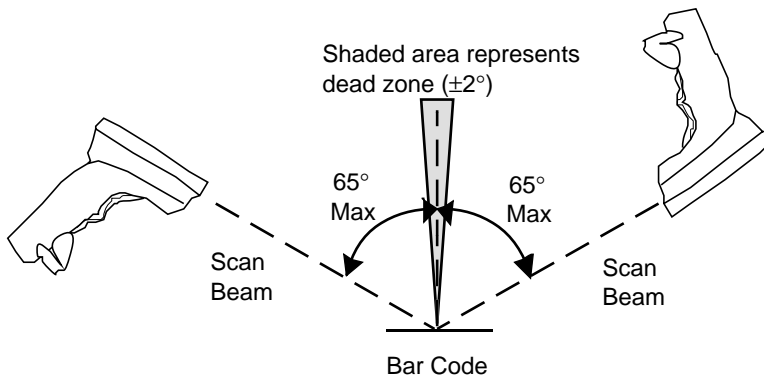

Figure 3-1. Maximum Tilt Angles and Dead Zone

## Scanning PDF417 (2-D) Bar Codes

---

Before scanning a PDF bar code, enable PDF417 scanning by using the parameter bar code in *ENABLE PDF417 on page 5-75*.

1. Aim the scanner at the PDF bar code and press the trigger.
2. Hold the trigger down and keep the scan line parallel to the rows of the symbol.
3. Manually raster the scan line by slowly moving the scanner up and down so it scans the entire bar code.

If PDF Decode Feedback is enabled, an audible feedback “clicking” lets you know the bar code is being decoded. If this parameter is enabled but there’s no clicking noise when you’re scanning the bar code, it’s not being scanned properly.

- ◆ Check that PDF417 scanning is enabled.
- ◆ Make sure the scan line extends at least 1/2” past the left and right edges of the bar code.
- ◆ Hold the scanner closer for denser symbols, farther away for larger symbols.
- ◆ Make sure you scan the top and bottom rows of the symbol.
- ◆ Be patient - it may take a few swipes to decode the symbol.

The bar code has been completely decoded when you hear a tone, followed by a short, high tone beep. The yellow LED on the rear of the scanner turns green. The green LED stays lit for two seconds or until the next trigger pull.



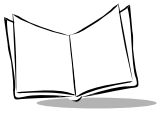

## What If...

---

### ***Nothing happens when you follow the operating instructions?***

#### **You Should**

- ◆ Check the system power. Is there a battery in the battery box?
- ◆ Be sure the scanner is programmed for the terminal in use.
- ◆ Make sure the scanner is programmed to read the type of bar code you are scanning.
- ◆ Check for loose cable connections.
- ◆ Check the symbol to make sure it is not defaced.
- ◆ Try scanning test symbols of the same code type.

### ***Symbol is decoded, but not transmitted to the host terminal?***

#### **You Should**

- ◆ Be sure the proper host type is selected (See [Chapter 5](#)).

### ***Scanned data is incorrectly displayed on the terminal?***

#### **You Should**

- ◆ Make sure the system is programmed for the correct keyboard type.
- ◆ Make sure the CAPS LOCK key is off.
- ◆ Be sure the proper host is selected.
- ◆ Be sure editing options (e.g., UPC-E to UPC-A Conversion) are properly programmed.

---

**Note:** *If after performing these checks the symbol still does not scan, contact your distributor or call the [Symbol Support Center](#). See [page ii](#) for the telephone number.*

---

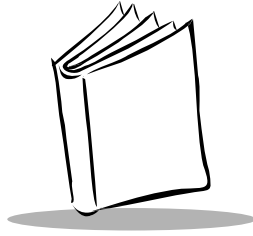

## *Chapter 4*

# *Maintenance & Specifications*

### **Maintenance**

---

Cleaning the exit window is the only maintenance required.

- ◆ Do not allow any abrasive material to touch the window.
- ◆ Remove any dirt particles with a damp cloth.
- ◆ Wipe the window using a damp cloth, and if necessary, a non-ammonia based detergent.
- ◆ Do not spray water or other cleaning liquids directly into the window.

### **Accessories**

---

#### ***Required Accessories***

LS 400Xi scanners are sent as a package with required accessories. Optional accessories are available at extra cost.

#### ***Optional Accessories***

Optional accessories include various stands and holders, which are supplied at extra cost. Additional units of standard accessories may also be purchased at extra cost.

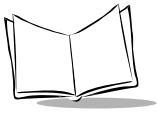

## Technical Specifications

Table 4-1. Technical Specifications

Item	Description
<b>Power Requirements*</b> <b>IBM 46XX/Synapse</b> <b>RS-232C/Synapse</b> <b>Low Power</b>	4.8 to 14 VDC (max) 200 mA @ 5V typical 4.8 to 14 VDC (max) 180 mA @ 5V typical 4.8 to 14 VDC (max) 2 mA @ 5V typical
<b>Decode Capability</b>	The LS 400Xi can be programmed to decode the following code types: UPC/EAN, Bookland EAN, Code 39, Code 39 Full ASCII, Trioptic Code 39, Code 93, Codabar, Interleaved 2 of 5, Code 128, EAN 128, Discrete 2 of 5, MSI Plessey, and PDF417. Set code length(s) for any linear code type. The LS 400Xi can auto-discriminate between all of the above code types except for Code 39 and Code 39 Full ASCII. Transmission of decoded information will depend on the capabilities of the attached terminal.
<b>Beeper Operation</b>	User-selectable: Enabled, Disabled
<b>Scan Repetition Rate</b>	100 scans/sec (bidirectional)
<b>Scan Angle</b>	30°
<b>Roll (Skew) Tolerance</b>	± 10° from normal
<b>Pitch</b>	± 65° from normal
<b>Yaw</b>	± 60° from normal
<b>1-D Decode Depth of Field</b>	See <a href="#">LS 400Xi 1-D Decode Zone on page 4-4</a>
<b>2-D Decode Depth of Field</b>	See <a href="#">LS 400Xi 2-D Decode Zone on page 4-5</a>
<b>Print Contrast Minimum</b>	20% absolute dark/light differential, measured at 675 nm.
*For direct host power connection, make sure the host terminal supplies sufficient power for the specified operation. Symbol is not responsible for damage to host equipment or system mis-operation due to an insufficient power condition.	

Table 4-1. Technical Specifications (Cont'd)

Item	Description	
<b>Ambient Light Immunity</b> <b>Artificial Lighting</b> <b>Sunlight</b>	200 ft. candles 8000 ft. candles codes)	2153 lux 86112 lux (@8 in. (20 cm) on low density bar
<b>Operating Temperature</b>	32° to 104°F	0° to 40°C
<b>Storage Temperature</b>	-40° to 140°F	-40° to 60°C
<b>Humidity</b>	5% to 95% (non-condensing)	
<b>Coil Cable Length</b>	9-12 ft.	274-365 cm (depending on host)
<b>Durability</b>	4-ft. drop to concrete	1.2 m
<b>Dimensions</b> <b>Height</b> <b>Length</b> <b>Width</b>	6.3 in. 5 in. 2.8 in.	16 cm 12.7 cm 7.1 cm
<b>Laser Classifications</b>	CDRH Class II IEC Class 1 IEC 825 Class 2	
<b>Laser Power</b>	.92 mW ±5%	

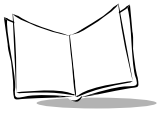

# LS 400Xi 1-D Decode Zone

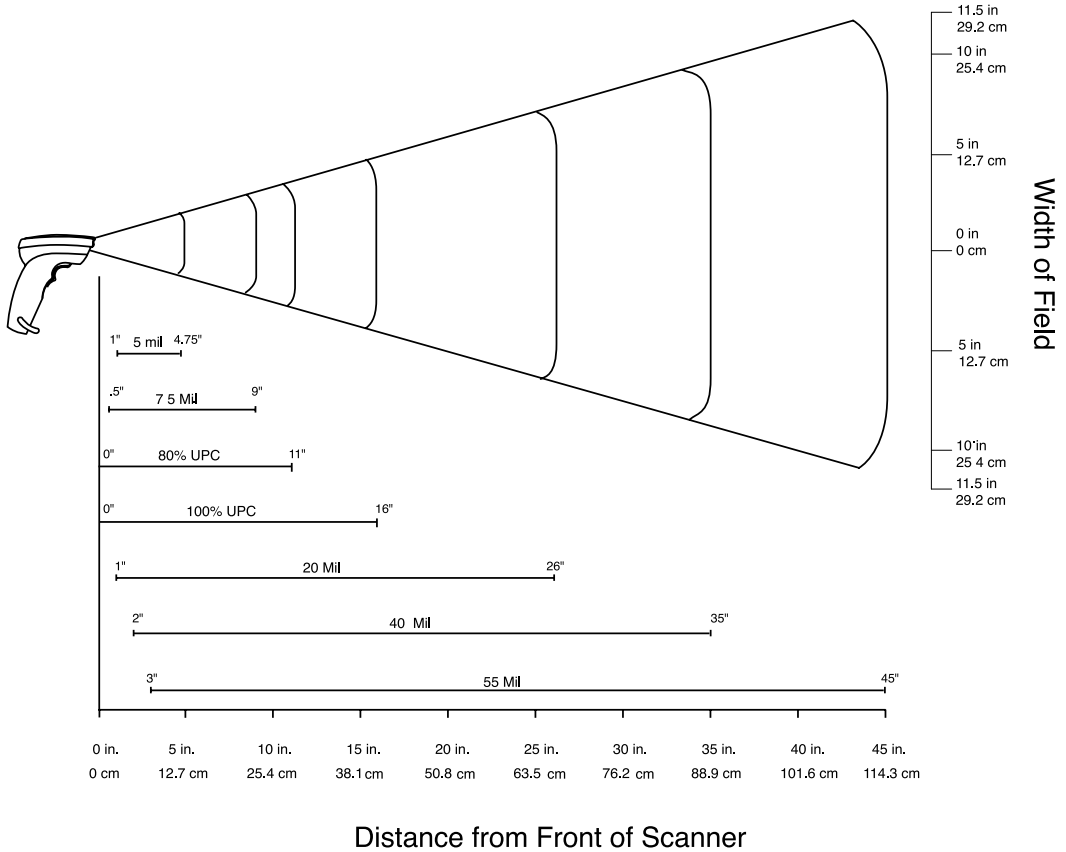

Figure 4-1. LS 400Xi 1-D Decode Zone

# LS 400Xi 2-D Decode Zone

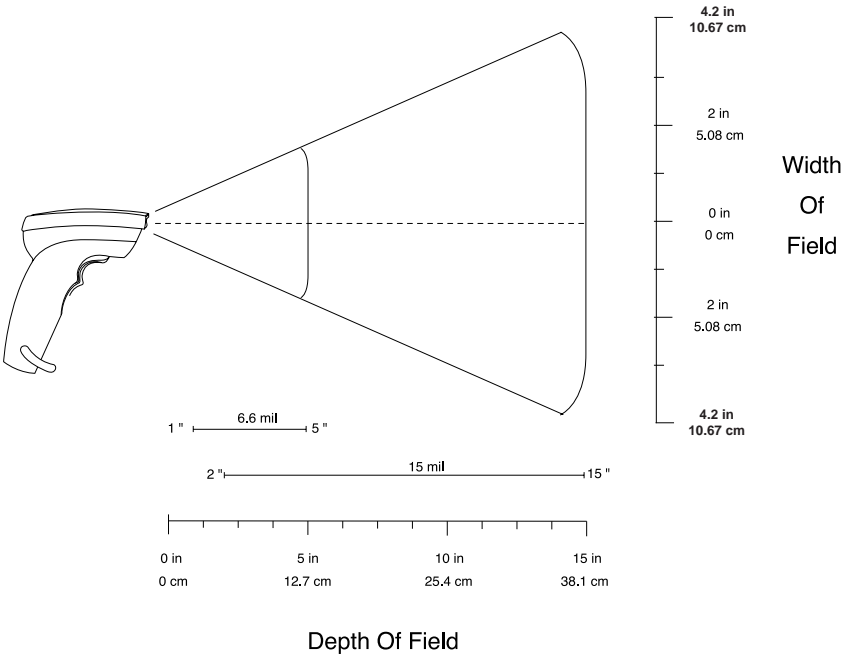
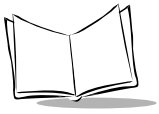

Figure 4-2. LS 400Xi 2-D Decode Zone

**Note:** The measurements above are for 6.6 mil, 100 character PDF bar code and 15 mil, 64 character PDF bar code.



## Pin-outs

---

Table 4-2. Pin-outs

<b>Pin</b>	<b>LS 4004I</b>	<b>LS 4005I</b>	<b>LS 4005I with EAS</b>
1	Reserved	Reserved	Reserved
2	Power	Power	Power
3	Ground	Ground	Ground
4	Synapse Data	Synapse Data	Synapse Data
5	Synapse Clock	Synapse Clock	Synapse Clock
6	RxD	B IBM SERIAL	B IBM SERIAL
7	TxD	A IBM SERIAL	A IBM SERIAL
8	DTR	Not used	Shield
9	CTS	Not used	EAS 1
10	RTS	Not used	EAS 2

# Beeper Indications

Table 4-3. Beeper Indications

Beeper Sequence	Indication
<b>Standard Use</b>	
<b>Short high tone</b>	A bar code symbol was decoded (if decode beeper is enabled).
<b>Low tone, followed by short high tone</b>	A PDF417 bar code symbol was decoded (if decode beeper is enabled).
<b>Clicking</b>	A PDF417 bar code symbol is being decoded (if <i>PDF Decode Feedback</i> is enabled).
<b>4 Beeps - long low tone</b>	A transmission error has been detected in a scanned symbol. The data is ignored. This occurs if a unit is not properly configured. Check option settings.
<b>5 Beeps - low tone</b>	Convert or format error
<b>Lo/hi/lo tone</b>	ADF transmit error
<b>Hi/hi/hi/lo tone</b>	RS-232 receive error
<b>Parameter Menu Scanning</b>	
<b>Short high tone</b>	Correct entry scanned or correct menu sequence performed.
<b>Lo/hi tone</b>	Input error, incorrect bar code or "Cancel" scanned, wrong entry, incorrect bar code programming sequence; remain in program mode.
<b>Hi/lo tone</b>	Keyboard parameter selected. Enter value using bar code keypad.
<b>Hi/lo/hi/lo tone</b>	Successful program exit with change in the parameter setting.

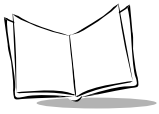

**Table 4-3. Beeper Indications (Cont'd)**

<b>Code 39 Buffering</b>	
<b>Hi/lo tone</b>	New Code 39 data was entered into the buffer.
<b>3 Beeps - long high tone</b>	Code 39 buffer is full.
<b>Lo/hi/lo tone</b>	The buffer was erased, or there was an attempt to transmit an empty buffer. When the Code 39 buffer was empty, the scanner read a command to clear or to transmit a Code 39 buffer.
<b>4 Beeps - long low tone</b>	Error in data transmission.
<b>Lo/hi tone</b>	A successful transmission of buffered data.

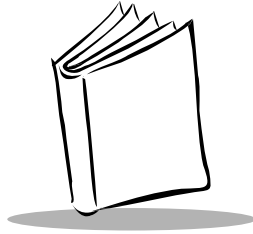

## Chapter 5 Parameter Menus

### Operational Parameters

---

The LS 400Xi is shipped with the settings shown in the [Default Table on page 5-2](#). These default values are stored in non-volatile memory and are preserved even when the scanner is powered down. You can change these default values by scanning the appropriate bar codes included in this manual. These new values replace the standard default values in memory. The default parameter values can be recalled by scanning the [SET ALL DEFAULTS bar code on page 5-7](#).

---

**Note:** *The ability to scan PDF417 bar codes is not enabled by default. You must program the scanner to read PDF417 bar codes by scanning the [ENABLE PDF417 bar code on page 5-75](#).*

---

Even if the default parameters suit your needs, you must still select a terminal type. The scanner automatically identifies the host type on power-up (provided the host is powered-up before the scanner is attached to it). You must then select the appropriate terminal type for that host. For example, if the scanner is connected to an IBM 4683, after you hear the power-up beeps, select the proper port from the choices on page [5-8](#). The same applies to all other host types.

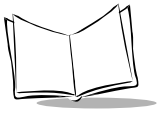

The following table lists the defaults for all parameters. If you wish to change any option, scan the appropriate bar code(s).

**Table 5-1. Default Table**

<b>Parameter</b>	<b>Default</b>	<b>Page Number</b>
Set Default Parameter	All Defaults	5-7
Host Type	See page 5-1	5-8
Beeper Tone	High Frequency	5-12
Beeper Volume	High	5-13
Laser On Time	3.0 seconds	5-14
Power Mode	Low Power	5-15
Beep After Good Decode	Enable	5-16
Transmit "No Read" Message	Disable	5-17
PDF Decode Feedback	Enable	5-18
Linear Code Type Security Levels	1	5-19
Bi-directional Redundancy	Disable	5-21
<b>UPC/EAN</b>		
UPC-A	Enable	5-22
UPC-E	Enable	5-22
UPC-E1	Disable	5-22
EAN-8	Enable	5-23
EAN-13	Enable	5-23
Bookland EAN	Disable	5-24
Decode UPC/EAN Supplementals	Ignore	5-25

Table 5-1. Default Table (Cont'd)

<b>Parameter</b>	<b>Default</b>	<b>Page Number</b>
Decode UPC/EAN Supplemental Redundancy	7	<a href="#">5-26</a>
Transmit UPC-A Check Digit	Enable	<a href="#">5-27</a>
Transmit UPC-E Check Digit	Enable	<a href="#">5-27</a>
Transmit UPC-E1 Check Digit	Enable	<a href="#">5-27</a>
UPC-A Preamble	System Character	<a href="#">5-28</a>
UPC-E Preamble	System Character	<a href="#">5-29</a>
UPC-E1 Preamble	System Character	<a href="#">5-30</a>
Convert UPC-E to A	Disable	<a href="#">5-31</a>
Convert UPC-E1 to A	Disable	<a href="#">5-32</a>
EAN-8 Zero Extend	Disable	<a href="#">5-33</a>
Convert EAN-8 to EAN-13 Type	Type is EAN-8	<a href="#">5-34</a>
UPC/EAN Security Levels	0	<a href="#">5-35</a>
UPC/EAN Coupon Code	Disable	<a href="#">5-37</a>
<b>Code 128</b>		
Code 128	Enable	<a href="#">5-38</a>
UCC/EAN-128	Disable	<a href="#">5-39</a>
<b>Code 39</b>		
Code 39	Enable	<a href="#">5-40</a>
Trioptic Code 39	Disable	<a href="#">5-41</a>
Convert Code 39 to Code 32	Disable	<a href="#">5-42</a>
Code 32 Prefix	Disable	<a href="#">5-43</a>

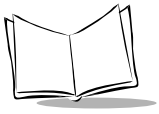

Table 5-1. Default Table (Cont'd)

Parameter	Default	Page Number
Set Length(s) for Code 39	2 to 55	<a href="#">5-44</a>
Code 39 Check Digit Verification	Disable	<a href="#">5-46</a>
Transmit Code 39 Check Digit	Disable	<a href="#">5-47</a>
Code 39 Full ASCII Conversion	Disable	<a href="#">5-48</a>
Buffer Code 39	Disable	<a href="#">5-49</a>
<b>Code 93</b>		
Code 93	Disable	<a href="#">5-52</a>
Set Length(s) for Code 93	4-55	<a href="#">5-53</a>
<b>Interleaved 2 of 5</b>		
Interleaved 2 of 5	Enable	<a href="#">5-55</a>
Set Length(s) for I 2 of 5	14	<a href="#">5-56</a>
I 2 of 5 Check Digit Verification	Disable	<a href="#">5-58</a>
Transmit I 2 of 5 Check Digit	Disable	<a href="#">5-59</a>
Convert I 2 of 5 to EAN 13	Disable	<a href="#">5-60</a>
<b>Discrete 2 of 5</b>		
Discrete 2 of 5	Disable	<a href="#">5-61</a>
Set Length(s) for D 2 of 5	12	<a href="#">5-62</a>

Table 5-1. Default Table (Cont'd)

Parameter	Default	Page Number
<b>Codabar</b>		
Codabar	Disable	5-64
Set Lengths for Codabar	5-55	5-66
CLSI Editing	Disable	5-67
NOTIS Editing	Disable	5-68
<b>MSI Plessey</b>		
MSI Plessey	Disable	5-69
Set Length(s) for MSI Plessey	Any Length	5-71
MSI Plessey Check Digits	One	5-72
Transmit MSI Plessey Check Digit	Disable	5-73
MSI Plessey Check Digit Algorithm	Mod 10/Mod 10	5-74
<b>PDF</b>		
Enable/Disable PDF	Disable	5-75
<b>Data Options</b>		
Transmit Code ID Character	None	5-77
Pause Duration	0	5-78
Prefix/Suffix Values	7013 (<CR/LF> for serial)	5-79
Scan Data Transmission Format	Data as is	5-80

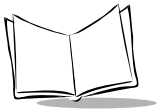

Table 5-1. Default Table (Cont'd)

<b>Parameter</b>	<b>Default</b>	<b>Page Number</b>
<b>RS-232C</b>		
RS-232 Host Type	Standard	<a href="#">5-11</a>
Baud Rate	9600	<a href="#">5-83</a>
Parity	None	<a href="#">5-85</a>
Check Receive Errors	Do Not Check	<a href="#">5-85</a>
Hardware Handshaking	None	<a href="#">5-87</a>
Software Handshaking	None	<a href="#">5-88</a>
Host Serial Response Time-out	2 Sec.	<a href="#">5-90</a>
RTS Line State	Low	<a href="#">5-90</a>
Stop Bit Select	1	<a href="#">5-91</a>
ASCII Format	8-Bit	<a href="#">5-91</a>
Beep on <BEL>	Disable	<a href="#">5-92</a>
Intercharacter Delay	0	<a href="#">5-92</a>

## Set Default Parameter

---

Scanning this bar code returns all parameters to the default values listed in [Table 5-1 on page 5-2](#).

---

**Note:** *The ability to scan PDF417 bar codes is not enabled by default. You must program the scanner to read PDF417 bar codes by scanning the [ENABLE PDF417](#) bar code on page 5-75.*

---



SET ALL DEFAULTS

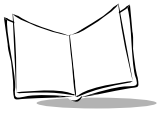

## Host Type

---

If you are using a Synapse cable, Synapse auto-detects your host so no host bar codes need to be scanned. Otherwise, use the following selections to select your host.

### **IBM 46XX Host Types**

To select one of the following as a POS Interface, scan the appropriate bar code below.

---

**Note:** *To properly communicate with 468X/9X terminals, the driver corresponding to the port being used must be loaded and enabled when you are configuring your terminal system. See your terminal's operating manual for details.*

---

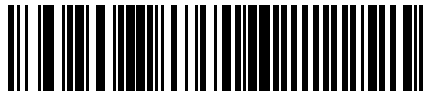

Port 5B

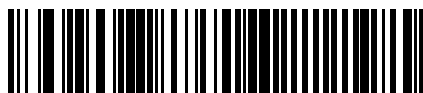

Port 9B

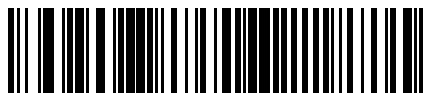

Port 17

## RS-232C Host Types

Three RS-232C hosts are set up with their own parameter default settings (Table 5-2). Selecting the ICL, Fujitsu, or Nixdorf RS-232C terminal sets the defaults listed below. These defaults take precedence over standard defaults. So if you select Fujitsu RS-232C, then select the standard defaults, the Fujitsu defaults still take precedence.

Table 5-2. Terminal Specific RS-232C

Parameter	Standard	ICL	FUJITSU	NIXDORF Mode A/ Mode B	PDT 3300**
<b>Transmit Code ID</b>	No	Yes	Yes	Yes	Yes
<b>Data Transmission Format</b>	Data as is	Data/Suffix	Data/Suffix	Data/Suffix	STX/Data/ ETX/LRC
<b>Suffix</b>	CR/LF (7013)	CR (1013)	CR (1013)	CR (1013)	None
<b>Baud Rate</b>	9600	9600	9600	9600	19200
<b>Parity</b>	None	Even	None	Odd	Even
<b>Hardware Handshaking</b>	None	RTS/CTS Option 3	None	RTS/CTS Option 3	RTS/CTS Standard
<b>Software Handshaking</b>	None	None	None	None	ACK/NAK
<b>Serial Response Time-out</b>	2 Sec.	9.9 Sec.	2 Sec.	9.9 Sec.	9.9 sec.
<b>Stop Bit Select</b>	One	One	One	One	One
<b>ASCII Format</b>	8-Bit	8-Bit	8-Bit	8-Bit	7-Bit
<b>Beep On &lt;BEL&gt;</b>	Disabled	Disabled	Disabled	Disabled	Disabled
<b>RTS Line State</b>	Low	High	Low	*Low = No data to send	Low

\*In the Nixdorf Mode B, if CTS is Low, scanning is disabled. When CTS is High, the user can scan bar codes.

\*\*If Nixdorf Mode B or PDT 3300 is scanned without the scanner connected to the proper host, it may appear unable to scan. If this happens, scan a different RS-232 host type within 5 seconds of cycling power to the scanner.

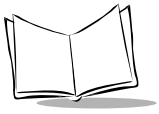

## RS-232C Host Types (Cont'd)

Selecting the ICL, Fujitsu, or Nixdorf RS-232C terminal enables the transmission of code ID characters as listed in [Table 5-3](#) below. These code ID characters are not programmable and are separate from the Transmit Code ID feature. The Transmit Code ID feature should not be enabled for these terminals.

Table 5-3. Terminal Specific Code ID Characters

	ICL	FUJITSU	NIXDORF
<b>UPC-A</b>	"A"	"A"	"A"
<b>UPC-E</b>	"E"	"E"	"C0"
<b>EAN-8</b>	"FF"	"FF"	"B"
<b>EAN-13</b>	"F"	"F"	"A"
<b>Code 39</b>	"C" <len>	None	"M"
<b>Codabar</b>	"N" <len>	None	"N"
<b>Code 128</b>	"L" <len>	None	"K"
<b>I 2 of 5</b>	"I" <len>	None	"I"
<b>Code 93</b>	None	None	"L"
<b>D 2 of 5</b>	"H" <len>	None	"H"
<b>UCC/EAN 128</b>	"L" <len>	None	"P"
<b>MSI/Plessey</b>	None	None	"O"
<b>Bookland EAN</b>	"F"	"F"	"A"
<b>Trioptic</b>	None	None	None

## RS-232C Host Types (Cont'd)

To select an RS-232C host interface, scan one of the following bar codes. If you are scanning PDF417 bar codes, only Standard RS-232C or PDT 3300 may be selected.



STANDARD RS-232C

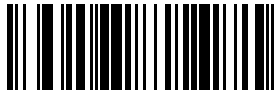

ICL RS-232C

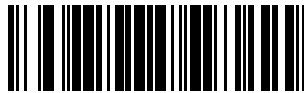

NIXDORF RS-232C Mode A



NIXDORF RS-232C Mode B



FUJITSU RS-232C



PDT 3300

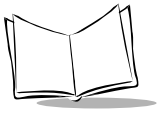

## Beeper Tone

---

To select a decode beep frequency (tone), scan the **LOW FREQUENCY**, **MEDIUM FREQUENCY**, or **HIGH FREQUENCY** bar code.



LOW FREQUENCY

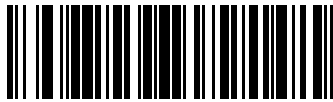

MEDIUM FREQUENCY

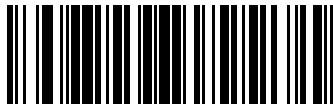

HIGH FREQUENCY

## Beeper Volume

---

To select a beeper volume, scan the **LOW VOLUME**, **MEDIUM VOLUME**, or **HIGH VOLUME** bar code.

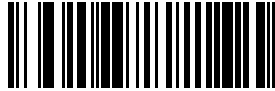

LOW VOLUME

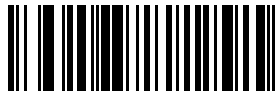

MEDIUM VOLUME



HIGH VOLUME

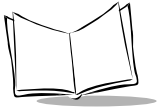

## Laser On Time

---

This parameter sets the maximum time decode processing continues during a scan attempt. It is programmable in 0.1 second increments from 0.5 to 9.9 seconds.

To set a Laser On Time, scan the bar code below. Next scan two numeric bar codes beginning on page [5-93](#) that correspond to the desired time on. Single digit numbers must have a leading zero. For example, to set an On Time of .5 seconds, scan the bar code below, then scan the “0” and “5” bar codes. If you make an error, or wish to change your selection, scan **CANCEL** on page [5-95](#).



LASER ON TIME

## Power Mode

---

This parameter determines whether or not power remains on after a decode attempt. When in low power mode, the scanner enters into a low power consumption mode to preserve battery life after each decode attempt. When in continuous power mode, power remains on after each decode attempt.

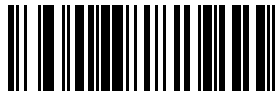

CONTINUOUS ON



LOW POWER

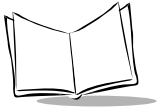

## Beep After Good Decode

---

Scan a bar code below to select whether or not the unit beeps after a good decode. If **DO NOT BEEP** is selected, the beeper still operates during parameter menu scanning and indicates error conditions.

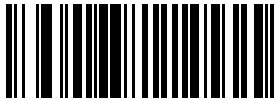

**BEEP AFTER GOOD DECODE**



**DO NOT BEEP AFTER GOOD DECODE**

## Transmit “No Read” Message

---

Scan a bar code below to select whether or not a “No Read” message is transmitted. When enabled, if a symbol does not decode, “NR” is transmitted. Any prefixes or suffixes which have been enabled are appended around this message. When disabled, if a symbol does not read, nothing is sent to the host.



ENABLE NO READ



DISABLE NO READ

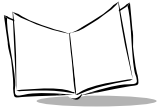

## PDF Decode Feedback

---

Scan a bar code below to select whether or not the unit “clicks” during PDF417 decoding to indicate proper alignment, motion, and distance.



**ENABLE PDF DECODE FEEDBACK**



**DISABLE PDF DECODE FEEDBACK**

## Linear Code Type Security Level

---

The LS 400Xi offers four levels of decode security for linear code types (e.g., Code 39, Interleaved 2 of 5). Higher security levels are selected for decreasing levels of bar code quality. As security levels increase, the scanner's aggressiveness decreases. Select the security level appropriate for your bar code quality.

---

**Note:** *This does not apply to Code 128.*

---

### ***Linear Security Level 1***

The following code types must be successfully read twice before being decoded:

<b>Code Type</b>	<b>Length</b>
Codabar	All
MSI Plessey	4 or less
D 2 of 5	8 or less
I 2 of 5	8 or less

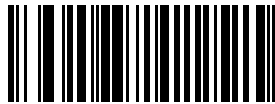

LINEAR SECURITY LEVEL 1

### ***Linear Security Level 2***

All code types must be successfully read twice before being decoded.

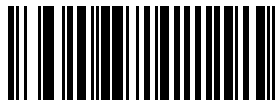

LINEAR SECURITY LEVEL 2

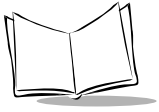

## **Linear Security Level 3**

Code types other than the following must be successfully read twice before being decoded. The following codes must be read three times:

<b>Code Type</b>	<b>Length</b>
MSI Plessey	4 or less
D 2 of 5	8 or less
I 2 of 5	8 or less
Codabar	8 or less

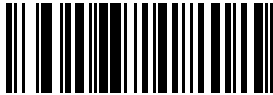

**LINEAR SECURITY LEVEL 3**

## **Linear Security Level 4**

All code types must be successfully read three times before being decoded.

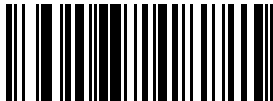

**LINEAR SECURITY LEVEL 4**

## Bi-directional Redundancy

---

This parameter is only valid when a *Linear Code Type Security Level* (see page 5-19) has been enabled. When this parameter is enabled, a bar code must be successfully scanned in both directions (forward and reverse) before being decoded.

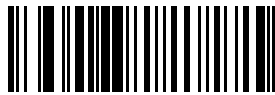

ENABLE BI-DIRECTIONAL REDUNDANCY

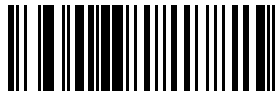

DISABLE BI-DIRECTIONAL REDUNDANCY

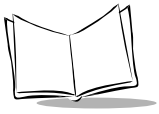

## Enable/Disable UPC-E/UPC-A/UPC-E1

---

To enable or disable UPC-E, UPC-A or UPC-E1, scan the appropriate bar code below.

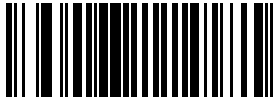

ENABLE UPC-E

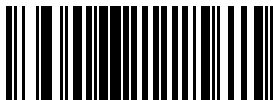

DISABLE UPC-E

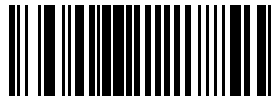

ENABLE UPC-A

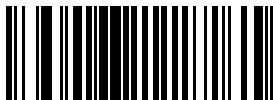

DISABLE UPC-A



ENABLE UPC-E1



DISABLE UPC-E1

## Enable/Disable EAN-8/EAN-13

---

To enable or disable EAN-8 or EAN-13, scan the appropriate bar code below.

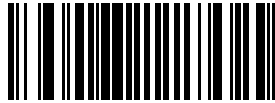

ENABLE EAN-8

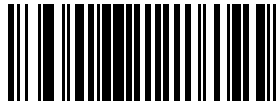

DISABLE EAN-8

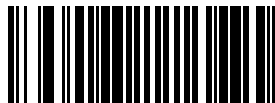

ENABLE EAN-13

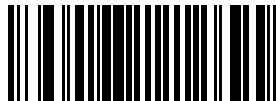

DISABLE EAN-13

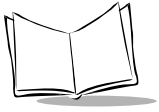

## **Enable/Disable Bookland EAN**

---

To enable or disable Bookland EAN, scan the appropriate bar code below.

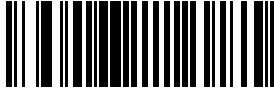

**ENABLE BOOKLAND EAN**

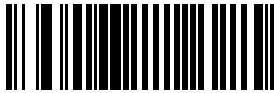

**DISABLE BOOKLAND EAN**

## Decode UPC/EAN Supplementals

---

Supplementals are additionally appended characters (2 or 5) according to specific code format conventions (e.g., UPC A+2, UPC E+2, EAN 8+2). Three options are available.

- ◆ If UPC/EAN with supplemental characters is selected, UPC/EAN symbols without supplemental characters are not decoded.
- ◆ If UPC/EAN without supplemental characters is selected, and the LS 400Xi is presented with a UPC/EAN plus supplemental symbol, the UPC/EAN is decoded and the supplemental characters ignored.
- ◆ An autodiscriminate option is also available. If this option is selected, choose an appropriate *Decode UPC/EAN Supplemental Redundancy* value from the next page. A value of 5 or more is recommended.

---

**Note:** *In order to minimize the risk of invalid data transmission, it is recommended that you select whether to read or ignore supplemental characters.*

---

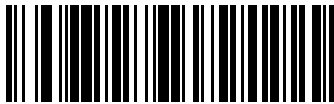

DECODE UPC/EAN WITH SUPPLEMENTALS

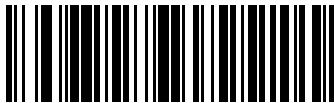

IGNORE UPC/EAN WITH SUPPLEMENTALS



AUTODISCRIMINATE UPC/EAN SUPPLEMENTALS

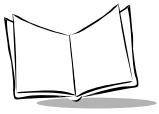

## Decode UPC/EAN Supplemental Redundancy

---

With Autodiscriminate UPC/EAN Supplementals selected, this option adjusts the number of times a symbol without supplementals is decoded before transmission. The range is from two to twenty times. Five or above is recommended when decoding a mix of UPC/EAN symbols with and without supplementals, and the autodiscriminate option is selected.

Scan the bar code below to select a decode redundancy value. Next scan two numeric bar codes beginning on page [5-93](#). Single digit numbers must have a leading zero. If you make an error, or wish to change your selection, scan **CANCEL** on page [5-95](#).

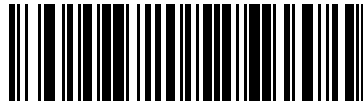

DECODE UPC/EAN  
SUPPLEMENTAL REDUNDANCY

## Transmit UPC-A/UPC-E/UPC-E1 Check Digit

---

Scan the appropriate bar code below to transmit the symbol with or without the UPC-A, UPC-E or UPC-E1 check digit.

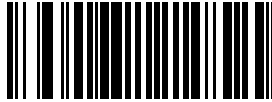

TRANSMIT UPC-A CHECK DIGIT

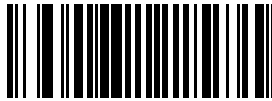

DO NOT TRANSMIT UPC-A CHECK DIGIT

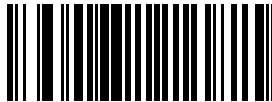

TRANSMIT UPC-E CHECK DIGIT

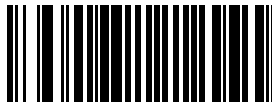

DO NOT TRANSMIT UPC-E CHECK DIGIT

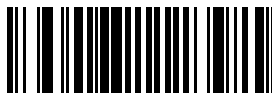

TRANSMIT UPC-E1 CHECK DIGIT

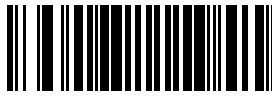

DO NOT TRANSMIT UPC-E1 CHECK DIGIT

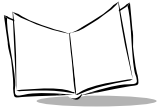

## UPC-A Preamble

---

Three options are given for lead-in characters for UPC-A symbols transmitted to the host device: transmit system character only, transmit system character and country code ("0" for USA), and no preamble transmitted. The lead-in characters are considered part of the symbol.

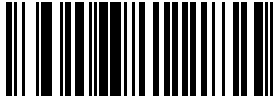

**NO PREAMBLE**  
(<DATA>)

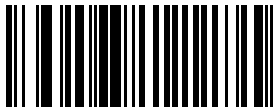

**SYSTEM CHARACTER**  
(<SYSTEM CHARACTER> <DATA>)

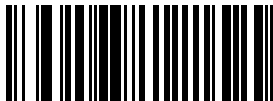

**SYSTEM CHARACTER & COUNTRY CODE**  
(< COUNTRY CODE> <SYSTEM CHARACTER> <DATA>)

## UPC-E Preamble

---

Three options are given for lead-in characters for UPC-E symbols transmitted to the host device: transmit system character only, transmit system character and country code ("0" for USA), and no preamble transmitted. The lead-in characters are considered part of the symbol.

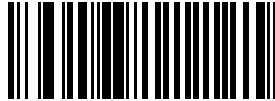

**NO PREAMBLE**  
(<DATA>)

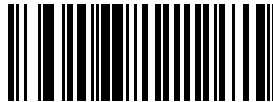

**SYSTEM CHARACTER**  
(<SYSTEM CHARACTER> <DATA>)

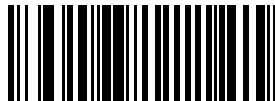

**SYSTEM CHARACTER & COUNTRY CODE**  
UPC(< COUNTRY CODE> <SYSTEM CHARACTER> <DATA>)

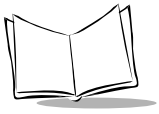

## UPC-E1 Preamble

---

Three options are given for lead-in characters for UPC-E1 symbols transmitted to the host device: transmit system character only, transmit system character and country code ("0" for USA), and no preamble transmitted. The lead-in characters are considered part of the symbol.

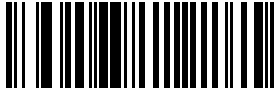

**NO PREAMBLE**  
(<DATA>)

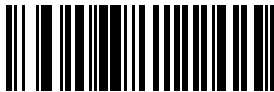

**SYSTEM CHARACTER**  
(<SYSTEM CHARACTER> <DATA>)



**SYSTEM CHARACTER & COUNTRY CODE**  
(< COUNTRY CODE> <SYSTEM CHARACTER> <DATA>)

## Convert UPC-E to UPC-A

---

This parameter converts UPC-E (zero suppressed) decoded data to UPC-A format before transmission. After conversion, data follows UPC-A format and is affected by UPC-A programming selections (e.g., Preamble, Check Digit).

Scanning **DO NOT CONVERT UPC-E TO UPC-A** allows you to transmit UPC-E (zero suppressed) decoded data.

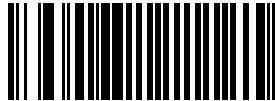

CONVERT UPC-E TO UPC-A  
(ENABLE)

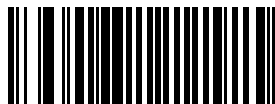

DO NOT CONVERT UPC-E TO UPC-A  
(DISABLE)

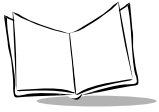

## Convert UPC-E1 to UPC-A

---

This parameter converts UPC-E1 decoded data to UPC-A format before transmission. After conversion, data follows UPC-A format and is affected by UPC-A programming selections (e.g., Preamble, Check Digit).

Scanning **DO NOT CONVERT UPC-E1 TO UPC-A** allows you to transmit UPC-E1 decoded data.

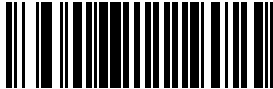

**CONVERT UPC-E1 TO UPC-A  
(ENABLE)**



**DO NOT CONVERT UPC-E1 TO UPC-A  
(DISABLE)**

## EAN Zero Extend

---

If this parameter is enabled, five leading zeros are added to decoded EAN-8 symbols to make them compatible in format to EAN-13 symbols.

Disabling this parameter returns EAN-8 symbols to their normal format.

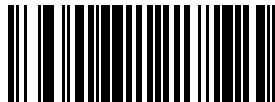

ENABLE EAN ZERO EXTEND

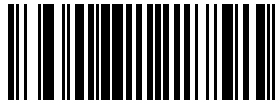

DISABLE EAN ZERO EXTEND

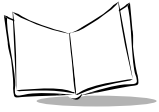

## Convert EAN-8 to EAN-13 Type

---

When EAN Zero Extend is enabled, this parameter gives you the option of labeling the extended symbol as either an EAN-13 bar code, or an EAN-8 bar code. This affects Transmit Code ID Character.

When EAN Zero Extend is disabled, this parameter has no effect on bar code data.

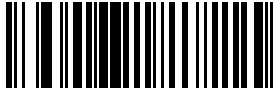

TYPE IS EAN-8



TYPE IS EAN-13

## UPC/EAN Security Level

---

The LS 400Xi offers four levels of decode security for UPC/EAN bar codes. Increasing levels of security are provided for decreasing levels of bar code quality. There is an inverse relationship between security and scanner aggressiveness, so be sure to choose only that level of security necessary for any given application.

### *UPC/EAN Security Level 0*

This is the default setting which allows the scanner to operate in its most aggressive state, while providing sufficient security in decoding “in-spec” UPC/EAN bar codes.

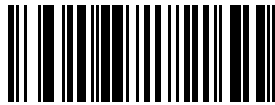

UPC/EAN SECURITY LEVEL 0

### *UPC/EAN Security Level 1*

As bar code quality levels diminish, certain characters become prone to misdecodes before others (i.e., 1, 2, 7, 8). If you are experiencing misdecodes of poorly printed bar codes, and the mis-decodes are limited to these characters, select this security level.

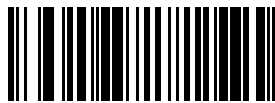

UPC/EAN SECURITY LEVEL 1

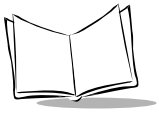

## ***UPC/EAN Security Level 2***

If you are experiencing misdecodes of poorly printed bar codes, and the misdecodes are not limited to characters 1, 2, 7, and 8, select this security level.

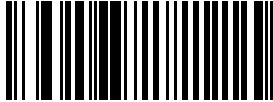

**UPC/EAN SECURITY LEVEL 2**

## ***UPC/EAN Security Level 3***

If you have tried Security Level 2, and are still experiencing misdecodes, select this security level. Be advised, selecting this option is an extreme measure against misdecoding severely out of spec bar codes. Selection of this level of security significantly impairs the decoding ability of the scanner. If this level of security is necessary, you should try to improve the quality of your bar codes.

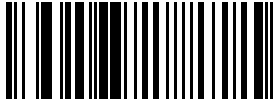

**UPC/EAN SECURITY LEVEL 3**

## UPC/EAN Coupon Code

---

When enabled, this parameter decodes UPC-A, UPC-A with 2 supplemental characters, UPC-A with 5 supplemental characters, and UPC-A/EAN 128 bar codes. *Autodiscriminate UPC/EAN With Supplemental Characters* must be enabled.

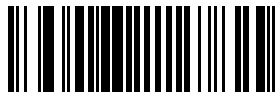

ENABLE UPC/EAN COUPON CODE

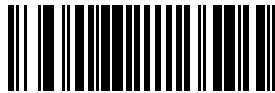

DISABLE UPC/EAN COUPON CODE

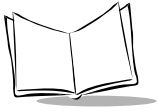

## **Enable/Disable Code 128**

---

To enable or disable Code 128, scan the appropriate bar code below.

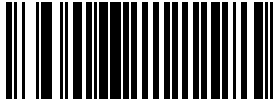

**ENABLE CODE 128**

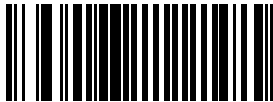

**DISABLE CODE 128**

## Enable/Disable UCC/EAN-128

---

To enable or disable UCC/EAN-128, scan the appropriate bar code below. (See [Appendix A](#) for details on [UCC/EAN-128](#).)

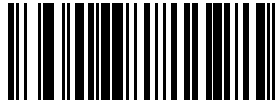

ENABLE UCC/EAN-128

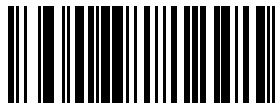

DISABLE UCC/EAN-128

## Lengths for Code 128

---

No length setting is required for Code 128. The default setting is Any Length.

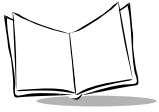

## **Enable/Disable Code 39**

---

To enable or disable Code 39, scan the appropriate bar code below.

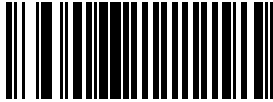

**ENABLE CODE 39**

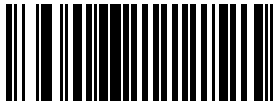

**DISABLE CODE 39**

## Enable/Disable Trioptic Code 39

---

Trioptic Code 39 symbols always contain six characters. To enable or disable Trioptic Code 39, scan the appropriate bar code below.

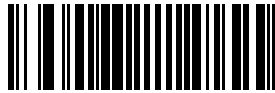

ENABLE TRIOPTIC CODE 39

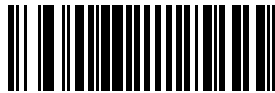

DISABLE TRIOPTIC CODE 39

---

**Note:** *Trioptic Code 39 and Code 39 Full ASCII cannot be enabled simultaneously. If you get an error beep when enabling Trioptic Code 39, disable Code 39 Full ASCII and try again.*

---

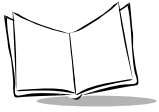

## Convert Code 39 to Code 32

---

Scan the appropriate bar code below to enable or disable converting Code 39 to Code 32.

---

**Note:** *Code 39 must be enabled in order for this parameter to function.*

---

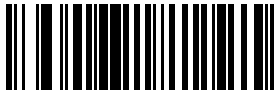

ENABLE CONVERT CODE 39 TO CODE 32

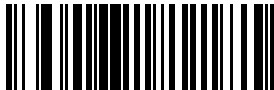

DISABLE CONVERT CODE 39 TO CODE 32

## Code 32 Prefix

---

Scan the appropriate bar code below to enable or disable adding the prefix character “A” to all Code 32 bar codes.

---

**Note:** *Convert Code 39 to Code 32 must be enabled for this parameter to function.*

---

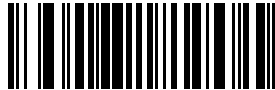

ENABLE CODE 32 PREFIX

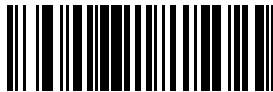

DISABLE CODE 32 PREFIX

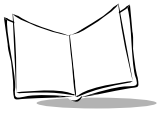

## Set Lengths for Code 39

---

Lengths for Code 39 may be set for any length, one or two discrete lengths, or lengths within a specific range. The length of a code refers to the number of characters (i.e., human readable characters), including check digit(s) the code contains. If Code 39 Full ASCII is enabled, **Length Within a Range** or **Any Length** are the preferred options.

**One Discrete Length** - This option allows you to decode only those codes containing a selected length. For example, if you select **Code 39 One Discrete Length**, then scan **1, 4**, only Code 39 symbols containing 14 characters are decoded. Numeric bar codes begin on page [5-93](#). If you make an error or wish to change your selection, scan **CANCEL** on page [5-95](#).



CODE 39 - ONE DISCRETE LENGTH

**Two Discrete Lengths** - This option allows you to decode only those codes containing two selected lengths. For example, if you select **Code 39 Two Discrete Lengths**, then scan **0, 2, 1, 4**, only Code 39 symbols containing 2 or 14 characters are decoded. Numeric bar codes begin on page [5-93](#). If you make an error or wish to change your selection, scan **CANCEL** on page [5-95](#).

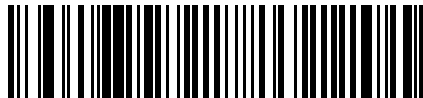

CODE 39 - TWO DISCRETE LENGTHS

## Set Lengths for Code 39 (Cont'd)

---

**Length Within Range** - This option allows you to decode a code type within a specified range. For example, to decode Code 39 symbols containing between 4 and 12 characters, first scan **Code 39 Length Within Range**. Then scan **0, 4, 1, and 2** (single digit numbers must always be preceded by a leading zero). Numeric bar codes begin on page [5-93](#). If you make an error or wish to change your selection, scan **CANCEL** on page [5-95](#).

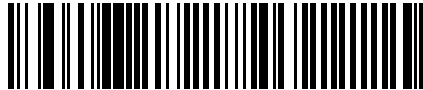

CODE 39 - LENGTH WITHIN RANGE

**Any Length** - Scanning this option allows you to decode Code 39 symbols containing any number of characters.

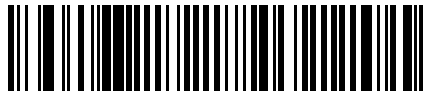

CODE 39 - ANY LENGTH

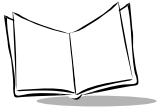

## Code 39 Check Digit Verification

---

When enabled, this parameter checks the integrity of a Code 39 symbol to ensure it complies with specified algorithms. Only those Code 39 symbols which include a modulo 43 check digit are decoded when this parameter is enabled.



**ENABLE CODE 39 CHECK DIGIT**

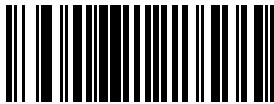

**DISABLE CODE 39 CHECK DIGIT**

## Transmit Code 39 Check Digit

---

Scan a bar code below to transmit data with or without the check digit.

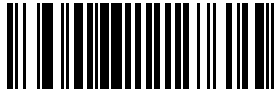

**TRANSMIT CODE 39 CHECK DIGIT  
(ENABLE)**

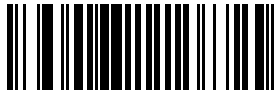

**DO NOT TRANSMIT CODE 39 CHECK DIGIT  
(DISABLE)**

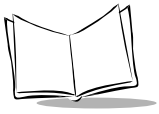

## Enable/Disable Code 39 Full ASCII

---

To enable or disable Code 39 Full ASCII, scan the appropriate bar code below.

When enabled, the ASCII character set assigns a code to letters, punctuation marks, numerals, and most control keystrokes on the keyboard.

The first 32 codes are non-printable and are assigned to keyboard control characters such as BACKSPACE and RETURN. The other 96 are called printable codes because all but SPACE and DELETE produce visible characters.

Code 39 Full ASCII interprets the bar code special character (\$ + % /) preceding a Code 39 character and assigns an ASCII character value to the pair. For example, when Code 39 Full ASCII is enabled and a +B is scanned, it is interpreted as **b**, %J as **?**, and \$H emulates the keystroke **BACKSPACE**. Scanning **ABC\$M** outputs the keystroke equivalent of **ABC ENTER**. Refer to [Table A-3](#) in [Appendix A](#).

The scanner does not autodiscriminate between Code 39 and Code 39 Full ASCII.

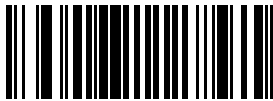

ENABLE CODE 39 FULL ASCII

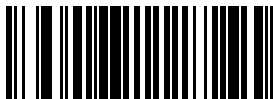

DISABLE CODE 39 FULL ASCII

---

**Note:** *Trioptic Code 39 and Code 39 Full ASCII cannot be enabled simultaneously. If you get an error beep when enabling Trioptic Code 39, disable Code 39 Full ASCII and try again.*

---

## Code 39 Buffering (Scan & Store)

---

When you select the scan and store option, all Code 39 symbols having a leading space as a first character are temporarily buffered in the unit to be transmitted later. The leading space is not buffered.

Decode of a valid Code 39 symbol with no leading space causes transmission in sequence of all buffered data in a first-in first-out format, plus transmission of the “triggering” symbol. See the following pages for further details.

When the scan and transmit option is selected, decoded Code 39 symbols without leading spaces are transmitted without being stored in the buffer.

Scan and Store affects Code 39 decodes only. If you select scan and store, we recommend that you configure the scanner to decode Code 39 symbology only.

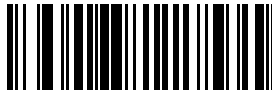

**BUFFER CODE 39  
(ENABLE)**



**DO NOT BUFFER CODE 39  
(DISABLE)**

While there is data in the transmission buffer, deleting Code 39 buffering capability via the parameter menu is not allowed. The buffer holds 200 bytes of information.

To allow disabling of Code 39 buffering, first force the buffer transmission (see [Transmit Buffer](#)) or clear the buffer. Both the **CLEAR BUFFER** and **TRANSMIT BUFFER** bar codes are length 1. *Be sure Code 39 length is set to include length 1.*

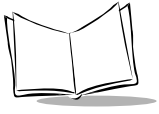

## **Buffer Data**

To buffer data, Code 39 buffering must be enabled, and a symbol must be read with a space immediately following the start pattern.

- ◆ Unless symbol overflows the transmission buffer, the unit gives a lo/hi beep to indicate successful decode and buffering. See [Overfilling Transmission Buffer](#).
- ◆ Unit adds the message, excluding the leading space to the transmission buffer.
- ◆ No transmission occurs.

## **Clear Transmission Buffer**

To clear the transmission buffer, read a symbol which contains only a start character, a dash (minus), and a stop character.

- ◆ Unit issues a short hi/lo/hi beep to signal that the transmission buffer has been erased, and no transmission has occurred.
- ◆ Unit erases the transmission buffer.
- ◆ No transmission occurs.

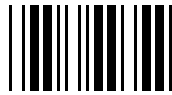

**CLEAR BUFFER**

## ***Transmit Buffer***

To transmit the buffer, read a symbol containing either the first or second condition:

1. Only a start character, a plus (+), and a stop character.
  - ◆ The unit signals that the transmission buffer has been sent (a lo/hi beep).
  - ◆ Unit sends the buffer.
  - ◆ Unit clears the buffer.



**TRANSMIT BUFFER**

2. A Code 39 bar code with leading character other than a space.
  - ◆ The unit signals a good decode and buffering of that decode has occurred by giving a hi/lo beep.
  - ◆ Unit transmits the buffer.
  - ◆ Unit signals that the buffer has been transmitted with a lo/hi beep.

## ***Overfilling Transmission Buffer***

If the symbol just read results in an overflow of the transmission buffer:

- ◆ Unit indicates that the symbol has been rejected by issuing three long, high beeps.
- ◆ No transmission occurs. Data in buffer is not affected.

## ***Attempt to Transmit an Empty Buffer***

If the symbol just read was the transmit buffer symbol and the Code 39 buffer is empty:

- ◆ A short lo/hi/lo beep signals that the buffer is empty.
- ◆ No transmission occurs.
- ◆ The buffer remains empty.

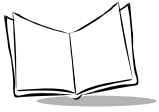

## **Enable/Disable Code 93**

---

To enable or disable Code 93, scan the appropriate bar code below.

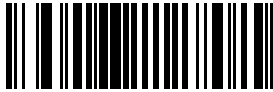

**ENABLE CODE 93**

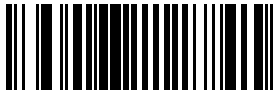

**DISABLE CODE 93**

## Set Lengths for Code 93

---

Lengths for Code 93 may be set for any length, one or two discrete lengths, or lengths within a specific range. The length of a code refers to the number of characters (i.e., human readable characters), including check digit(s) the code contains.

**One Discrete Length** - This option allows you to decode only those codes containing a selected length. For example, if you select **Code 93 One Discrete Length**, then scan **1, 4**, only Code 93 symbols containing 14 characters are decoded. Numeric bar codes begin on page [5-93](#). If you make an error or wish to change your selection, scan **CANCEL** on page [5-95](#).

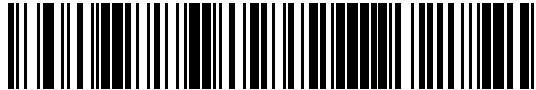

CODE 93 - ONE DISCRETE LENGTH

**Two Discrete Lengths** - This option allows you to decode only those codes containing two selected lengths. For example, if you select **Code 93 Two Discrete Lengths**, then scan **0, 2, 1, 4**, only Code 93 symbols containing 2 or 14 characters are decoded. Numeric bar codes begin on page [5-93](#). If you make an error or wish to change your selection, scan **CANCEL** on page [5-95](#).



CODE 93 - TWO DISCRETE LENGTHS

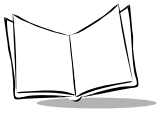

## Set Lengths for Code 93 (Cont'd)

---

**Length Within Range** - This option allows you to decode a code type within a specified range. For example, to decode Code 93 symbols containing between 4 and 12 characters, first scan **Code 93 Length Within Range**. Then scan **0, 4, 1, and 2** (single digit numbers must always be preceded by a leading zero). Numeric bar codes begin on page [5-93](#). If you make an error or wish to change your selection, scan **CANCEL** on page [5-95](#).

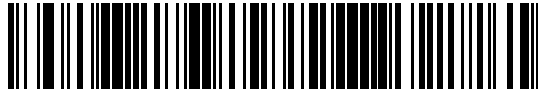

CODE 93 - LENGTH WITHIN RANGE

**Any Length** - Scanning this option allows you to decode Code 93 symbols containing any number of characters.



CODE 93 - ANY LENGTH

## Enable/Disable Interleaved 2 of 5

---

To enable or disable Interleaved 2 of 5, scan the appropriate bar code below.

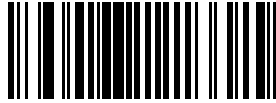

ENABLE INTERLEAVED 2 OF 5

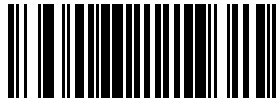

DISABLE INTERLEAVED 2 OF 5

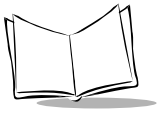

## Set Lengths for Interleaved 2 of 5

---

Lengths for I 2 of 5 may be set for any length, one or two discrete lengths, or lengths within a specific range. The length of a code refers to the number of characters (i.e., human readable characters) the code contains, and includes check digits.

**One Discrete Length** - This option allows you to decode only those codes containing a selected length. For example, if you select **I 2 of 5 One Discrete Length**, then scan **1, 4**, the only I 2 of 5 symbols decoded are those containing 14 characters. Numeric bar codes begin on page [5-93](#). If you make an error or wish to change your selection, scan **CANCEL** on page [5-95](#).

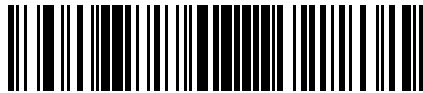

I 2 of 5 - ONE DISCRETE LENGTH

**Two Discrete Lengths** - This option allows you to decode only those codes containing two selected lengths. For example, if you select **I 2 of 5 Two Discrete Lengths**, then scan **0, 2, 1, 4**, the only I 2 of 5 symbols decoded are those containing 2 or 14 characters. Numeric bar codes begin on page [5-93](#). If you make an error or wish to change your selection, scan **CANCEL** on page [5-95](#).

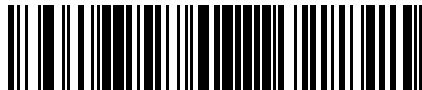

I 2 of 5 - TWO DISCRETE LENGTHS

## Set Lengths for Interleaved 2 of 5 (Cont'd)

---

**Length Within Range** - This option allows you to decode a code type within a specified range. For example, to decode I 2 of 5 symbols containing between 4 and 12 characters, first scan **I 2 of 5 Length Within Range**. Then scan **0, 4, 1, and 2** (single digit numbers must always be preceded by a leading zero). Numeric bar codes begin on page [5-93](#). If you make an error or wish to change your selection, scan **CANCEL** on page [5-95](#).

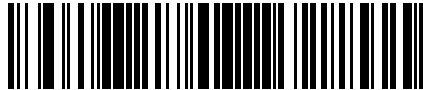

I 2 of 5 - LENGTH WITHIN RANGE

**Any Length** - Scanning this option allows you to decode I 2 of 5 symbols containing any number of characters.

---

**Note:** *Selecting this option may lead to misdecodes for I 2 of 5 codes.*

---



I 2 of 5 - ANY LENGTH

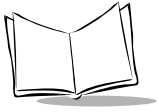

## I 2 of 5 Check Digit Verification

---

When enabled, this parameter checks the integrity of an I 2 of 5 symbol to ensure it complies a specified algorithm, either Uniform Symbology Specification (USS ), or Optical Product Code Council (OPCC).

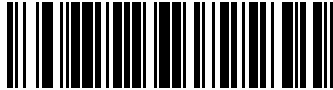

DISABLE

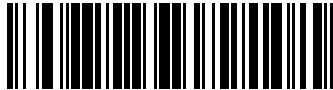

USS CHECK DIGIT



OPCC CHECK DIGIT

## Transmit I 2 of 5 Check Digit

---

Scan a bar code below to transmit data with or without the check digit.

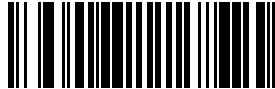

**TRANSMIT I 2 of 5 CHECK DIGIT  
(ENABLE)**



**DO NOT TRANSMIT I 2 of 5 CHECK DIGIT  
(DISABLE)**

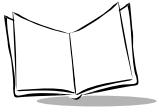

## Convert I 2 of 5 to EAN-13

---

This parameter converts a 14 character I 2 of 5 code into EAN-13, and transmits to the host as EAN-13. In order to accomplish this, the I 2 of 5 code must be enabled, one length must be set to 14, and the code must have a leading zero and a valid EAN-13 check digit.

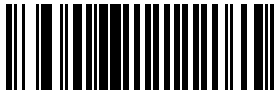

**CONVERT I 2 of 5 to EAN-13  
(ENABLE)**

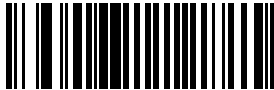

**DO NOT CONVERT I 2 of 5 to EAN-13  
(DISABLE)**

## Enable/Disable Discrete 2 of 5

---

To enable or disable Discrete 2 of 5, scan the appropriate bar code below.



ENABLE DISCRETE 2 OF 5



DISABLE DISCRETE 2 OF 5

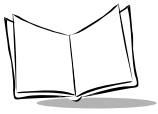

## Set Lengths for Discrete 2 of 5

---

Lengths for D 2 of 5 may be set for any length, one or two discrete lengths, or lengths within a specific range. The length of a code refers to the number of characters (i.e., human readable characters) the code contains, and includes check digits.

**One Discrete Length** - This option allows you to decode only those codes containing a selected length. For example, if you select **D 2 of 5 One Discrete Length**, then scan **1, 4**, the only D 2 of 5 symbols decoded are those containing 14 characters. Numeric bar codes begin on page [5-93](#). If you make an error or wish to change your selection, scan **CANCEL** on page [5-95](#).

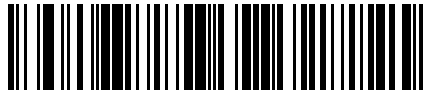

D 2 of 5 - ONE DISCRETE LENGTH

**Two Discrete Lengths** - This option allows you to decode only those codes containing two selected lengths. For example, if you select **D 2 of 5 Two Discrete Lengths**, then scan **0, 2, 1, 4**, the only D 2 of 5 symbols decoded are those containing 2 or 14 characters. Numeric bar codes begin on page [5-93](#). If you make an error or wish to change your selection, scan **CANCEL** on page [5-95](#).



D 2 of 5 - TWO DISCRETE LENGTHS

## Set Lengths for Discrete 2 of 5 (Cont'd)

---

**Length Within Range** - This option allows you to decode a code type within a specified range. For example, to decode D 2 of 5 symbols containing between 4 and 12 characters, first scan **D 2 of 5 Length Within Range**. Then scan **0, 4, 1, and 2** (single digit numbers must always be preceded by a leading zero). Numeric bar codes begin on page [5-93](#). If you make an error or wish to change your selection, scan **CANCEL** on page [5-95](#).

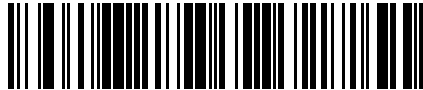

D 2 of 5 - LENGTH WITHIN RANGE

**Any Length** - Scanning this option allows you to decode D 2 of 5 symbols containing any number of characters.

---

**Note:** *Selecting this option may lead to misdecodes for D 2 of 5 codes.*

---



D 2 of 5 - ANY LENGTH

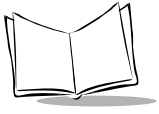

## **Enable/Disable Codabar**

---

To enable or disable Codabar, scan the appropriate bar code below.

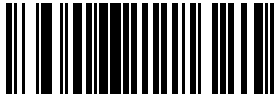

**ENABLE CODABAR**

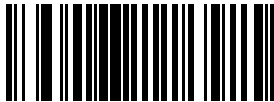

**DISABLE CODABAR**

## Set Lengths for Codabar

---

Lengths for Codabar may be set for any length, one or two discrete lengths, or lengths within a specific range. The length of a code refers to the number of characters (i.e., human readable characters) the code contains. It also includes any start or stop characters.

**One Discrete Length** - This option allows you to decode only those codes containing a selected length. For example, if you select **Codabar One Discrete Length**, then scan **1, 4**, the only Codabar symbols decoded are those containing 14 characters. Numeric bar codes begin on page [5-93](#). If you make an error or wish to change your selection, scan **CANCEL** on page [5-95](#).

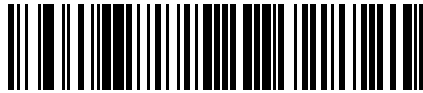

CODABAR - ONE DISCRETE LENGTH

**Two Discrete Lengths** - This option allows you to decode only those codes containing two selected lengths. For example, if you select **Codabar Two Discrete Lengths**, then scan **0, 2, 1, 4**, the only Codabar symbols decoded are those containing 2 or 14 characters. Numeric bar codes begin on page [5-93](#). If you make an error or wish to change your selection, scan **CANCEL** on page [5-95](#).

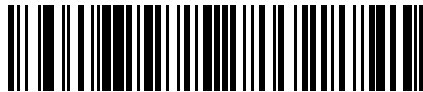

CODABAR - TWO DISCRETE LENGTHS

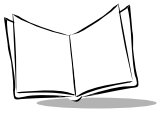

## Set Lengths for Codabar (Cont'd)

---

**Length Within Range** - This option allows you to decode a code type within a specified range. For example, to decode Codabar symbols containing between 4 and 12 characters, first scan **Codabar Length Within Range**. Then scan **0, 4, 1, and 2** (single digit numbers must always be preceded by a leading zero). Numeric bar codes begin on page [5-93](#). If you make an error or wish to change your selection, scan **CANCEL** on page [5-95](#).

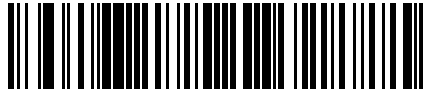

CODABAR - LENGTH WITHIN RANGE

**Any Length** - Scanning this option allows you to decode Codabar symbols containing any number of characters.



CODABAR - ANY LENGTH

## CLSI Editing

---

When enabled, this parameter strips the start and stop characters and inserts a space after the first, fifth, and tenth characters of a 14-character Codabar symbol.

---

**Note:** *Symbol length does not include start and stop characters.*

---

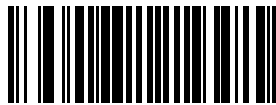

ENABLE CLSI EDITING

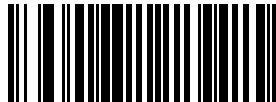

DISABLE CLSI EDITING

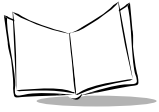

## NOTIS Editing

---

When enabled, this parameter strips the start and stop characters from a decoded Codabar symbol.

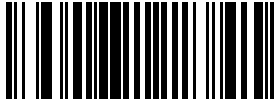

ENABLE NOTIS EDITING

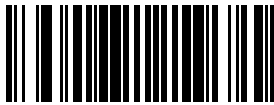

DISABLE NOTIS EDITING

## Enable/Disable MSI Plessey

---

To enable or disable MSI Plessey, scan the appropriate bar code below.

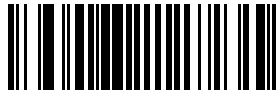

ENABLE MSI PLESSEY

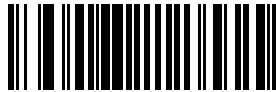

DISABLE MSI PLESSEY

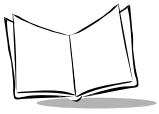

## Set Lengths for MSI Plessey

---

Lengths for MSI Plessey may be set for any length, one or two discrete lengths, or lengths within a specific range. The length of a code refers to the number of characters (i.e., human readable characters) the code contains, and includes check digits.

**One Discrete Length** - This option allows you to decode only those codes containing a selected length. For example, if you select **MSI Plessey One Discrete Length**, then scan **1, 4**, the only MSI Plessey symbols decoded are those containing 14 characters. Numeric bar codes begin on page [5-93](#). If you make an error or wish to change your selection, scan **CANCEL** on page [5-95](#).

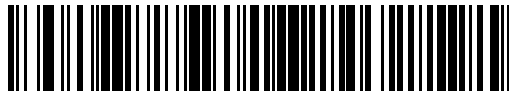

MSI PLESSEY - ONE DISCRETE LENGTH

**Two Discrete Lengths** - This option allows you to decode only those codes containing two selected lengths. For example, if you select **MSI Plessey Two Discrete Lengths**, then scan **0, 2, 1, 4**, the only MSI Plessey symbols decoded are those containing 2 or 14 characters. Numeric bar codes begin on page [5-93](#). If you make an error or wish to change your selection, scan **CANCEL** on page [5-95](#).

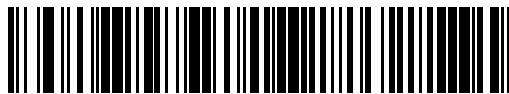

MSI PLESSEY - TWO DISCRETE LENGTHS

## Set Lengths for MSI Plessey (Cont'd)

---

**Length Within Range** - This option allows you to decode a code type within a specified range. For example, to decode MSI Plessey symbols containing between 4 and 12 characters, first scan **MSI Plessey Length Within Range**. Then scan **0, 4, 1, and 2** (single digit numbers must always be preceded by a leading zero). Numeric bar codes begin on page [5-93](#). If you make an error or wish to change your selection, scan **CANCEL** on page [5-95](#).

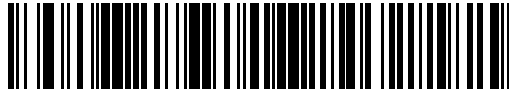

MSI PLESSEY - LENGTH WITHIN RANGE

**Any Length** - Scanning this option allows you to decode MSI Plessey symbols containing any number of characters.

---

**Note:** *Selecting this option may lead to misdecodes for MSI Plessey codes.*

---



MSI PLESSEY - ANY LENGTH

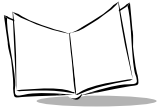

## MSI Plessey Check Digits

---

These check digits, located at the end of the bar code, verify the integrity of the data. At least one check digit is always required. Check digits are not automatically transmitted with the data (refer to [Transmit MSI Plessey Check Digit on page 5-73](#)).

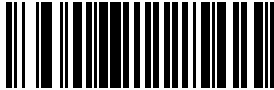

ONE MSI PLESSEY CHECK DIGIT

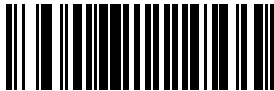

TWO MSI PLESSEY CHECK DIGIT

# Transmit MSI Plessey Check Digit

---

Scan a bar code below to transmit data with or without the check digit.

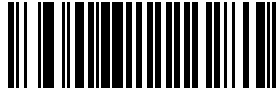

**TRANSMIT MSI PLESSEY CHECK DIGIT  
(ENABLE)**



**DO NOT TRANSMIT MSI PLESSEY CHECK DIGIT  
(DISABLE)**

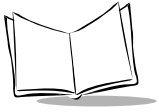

## MSI Plessey Check Digit Algorithm

---

When the two MSI Plessey check digits option is selected, an additional verification is required to ensure integrity. Either of the two following algorithms may be selected.

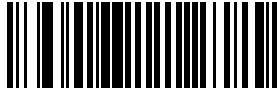

MOD 10/MOD 11



MOD 10/MOD 10

## Enable/Disable PDF417

---

Scan a bar code below to enable to disable PDF417 scanning capabilities.

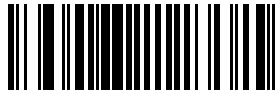

ENABLE PDF417

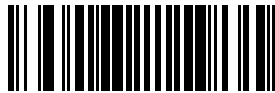

DISABLE PDF417

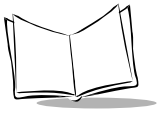

## Transmit Code ID Character

---

A code ID character identifies the code type of a scanned bar code. This may be useful when the scanner is decoding more than one code type. In addition to any single character prefix already selected, the code ID character is inserted between the prefix and the decoded symbol.

The user may select no code ID character, a Symbol Code ID character, or an AIM Code ID character. The Symbol Code ID characters are listed below; see [AIM Code Identifiers](#) in [Appendix A](#).

### **Symbol Code ID Characters**

A = UPC-A, UPC-E, UPC-E1, EAN-8, EAN-13

B = Code 39

C = Codabar

D = Code 128

E = Code 93

F = Interleaved 2 of 5

G = Discrete 2 of 5, or Discrete 2 of 5 IATA

J = MSI Plessey

K = UCC/EAN-128

L = Bookland EAN

M = Trioptic Code 39

N = Coupon Code

O = PDF417

## Transmit Code ID Character (Cont'd)

---

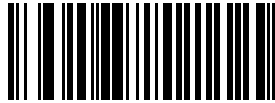

SYMBOL CODE ID CHARACTER

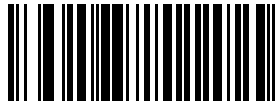

AIM CODE ID CHARACTER

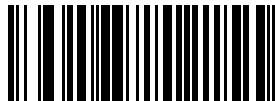

NONE

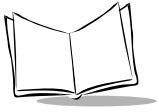

## Pause Duration

---

This parameter allows a pause to be inserted at any point in the data transmission. Pauses are set by scanning a two-digit number (i.e., two bar codes), and are measured in 1/10 second intervals. For example, scanning bar codes “0” and “1” inserts a 1/10 second pause; “0” and “5” gives you a 1/2 second delay. Numeric bar codes begin on page [5-93](#). If you make an error or wish to change your selection, scan **DATA FORMAT CANCEL** on page [5-81](#).

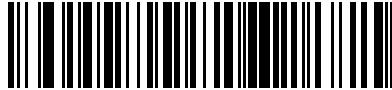

PAUSE DURATION

## Prefix/Suffix Values

---

A prefix/suffix may be appended to scan data for use in data editing. These values are set by scanning a four-digit number (i.e., four bar codes) that corresponds to key codes for various terminals. See [Table A-2](#) in [Appendix A](#) for conversion information. Numeric bar codes begin on page [5-93](#). If you make an error or wish to change your selection, scan **CANCEL** on page [5-95](#).

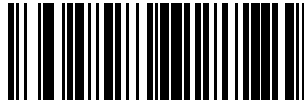

SCAN PREFIX

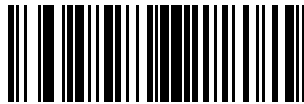

SCAN SUFFIX

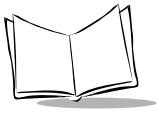

## Scan Data Transmission Format

---

To change the Scan Data Transmission Format, scan the **SCAN OPTIONS** bar code below. Then select one of four options. When you have made your selection, scan the **ENTER** bar code on the next page. If you make a mistake, scan the **DATA FORMAT CANCEL** bar code on the next page.

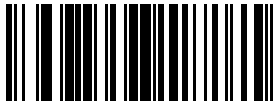

**SCAN OPTIONS**

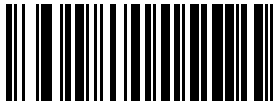

**DATA AS IS**

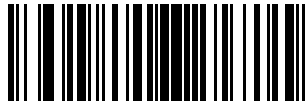

**<DATA> <SUFFIX>**

## Scan Data Transmission Format (Cont'd)

---

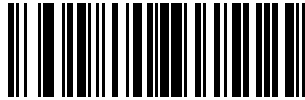

<PREFIX> <DATA>

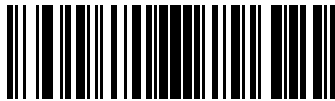

<PREFIX> <DATA> <SUFFIX>

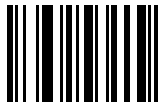

ENTER



DATA FORMAT CANCEL

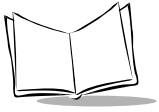

## RS-232C Parameters

---

### ***Baud Rate***

Baud rate is the number of bits of data transmitted per second. The scanner's baud rate setting should match the data rate setting of the host device. If not, data may not reach the host device or may reach it in distorted form.

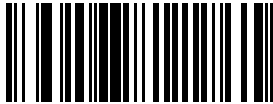

BAUD RATE 300

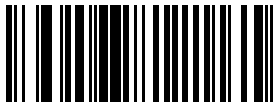

BAUD RATE 600



BAUD RATE 1200

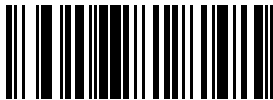

BAUD RATE 2400

## Baud Rate (Cont'd)

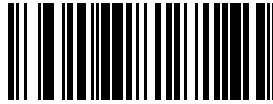

BAUD RATE 4800

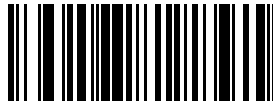

BAUD RATE 9600



BAUD RATE 19,200



BAUD RATE 38,400

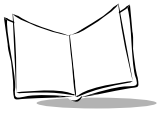

## Parity

A parity check bit is the most significant bit of each ASCII coded character. Select the parity type according to host device requirements.

If you select **ODD** parity, the parity bit has a value 0 or 1, based on data, to ensure than an odd number of 1 bits are contained in the coded character.

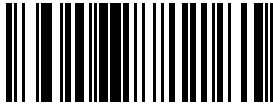

ODD

If you select **EVEN** parity, the parity bit has a value 0 or 1, based on data, to ensure than an even number of 1 bits are contained in the coded character.

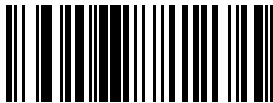

EVEN

Select **MARK** parity and the parity bit is always 1.

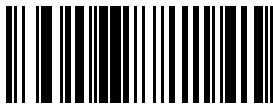

MARK

## Parity (Cont'd)

Select **SPACE** parity and the parity bit is always 0.

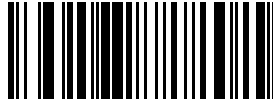

**SPACE**

If no parity is required, select **NONE**.



**NONE**

## Check Receive Errors

Select whether or not the parity, framing, and overrun of received characters are checked. The type of parity used is selectable through the **PARITY** parameter.

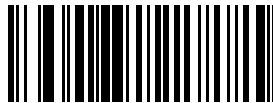

**CHECK FOR RECEIVED ERRORS**

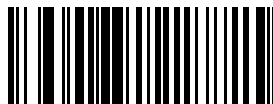

**DO NOT CHECK FOR RECEIVED ERRORS**



## Hardware Handshaking

The data interface consists of an RS-232C port. The port has been designed to operate either with or without the hardware handshaking lines, *Request to Send (RTS)*, and *Clear to Send (CTS)*.

If Standard RTS/CTS handshaking is selected, scan data is transmitted according to the following sequence:

- ◆ The controller reads the CTS line for activity. If CTS is asserted, the controller waits up to 2 seconds for the host to negate the CTS line. If, after 2 seconds (default), the CTS line is still asserted, the scanner sounds a transmit error and any scanned data is lost.
- ◆ When the CTS line is negated, the controller asserts the RTS line and waits up to 2 seconds for the host to assert CTS. When the host asserts CTS, data is transmitted. If, after 2 seconds (default), the CTS line is not asserted, the scanner sounds a transmit error and discards the data.
- ◆ When data transmission is complete, the controller negates RTS 10 msec after sending the last character.
- ◆ The host should respond by negating CTS. The controller checks for a negated CTS upon the next transmission of data.

During the transmission of data, the CTS line should be asserted. If CTS is deasserted for more than 50 ms between characters, the transmission is aborted, the scanner sounds a transmission error, and the data is discarded.

If the above communications sequence fails, the scanner issues an error indication. In this case, the data is lost and must be rescanned.

If Hardware Handshaking and Software Handshaking are both enabled, Hardware Handshaking takes precedence.

---

**Note:** *The DTR signal is jumpered active.*

---

## Hardware Handshaking (Cont'd)

### None

Scan the bar code below if no Hardware Handshaking is desired.

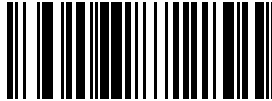

NONE

### Standard RTS/CTS

Scan the bar code below to select Standard RTS/CTS Hardware Handshaking.

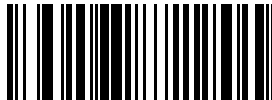

STANDARD RTS/CTS

### RTS/CTS Option 1

When RTS/CTS Option 1 is selected, the scanner asserts RTS before transmitting and ignores the state of CTS. The scanner deasserts RTS when the transmission is complete.

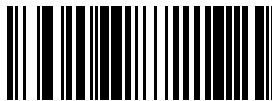

RTS/CTS OPTION 1

### RTS/CTS Option 2

When Option 2 is selected, RTS is always high or low (user-programmed logic level). However, the scanner waits for CTS to be asserted before transmitting data. If CTS is not asserted within 2 seconds (default), the scanner issues an error indication and discards the data.

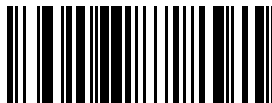

RTS/CTS OPTION 2

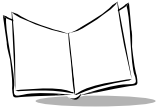

## **Hardware Handshaking (Cont'd)**

### **RTS/CTS Option 3**

When Option 3 is selected, the scanner asserts RTS prior to any data transmission, regardless of the state of CTS. The scanner waits up to 2 seconds (default) for CTS to be asserted. If CTS is not asserted during this time, the scanner issues an error indication and discards the data. The scanner deasserts RTS when transmission is complete.

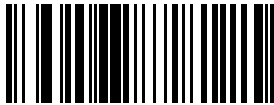

**RTS/CTS OPTION 3**

## **Software Handshaking**

This parameter offers control of the data transmission process in addition to, or instead of, that offered by hardware handshaking. There are five options.

If Software Handshaking and Hardware Handshaking are both enabled, Hardware Handshaking takes precedence.

### **None**

When this option is selected, data is transmitted immediately.

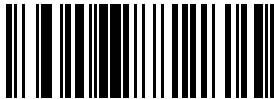

**NONE**

## **ACK/NAK**

When this option is selected, after transmitting data, the scanner expects either an ACK or NAK response from the host. Whenever a NAK is received, the scanner transmits the same data again and waits for either an ACK or NAK. After three unsuccessful attempts to send data when NAKs are received, the scanner issues an error indication and discards the data.

## Software Handshaking (Cont'd)

The scanner waits up to the programmable Host Serial Response Time-out to receive an ACK or NAK. If the scanner does not get a response in this time, it issues an error indication and discards the data. There are no retries when a time-out occurs.

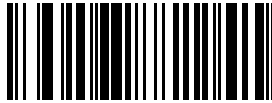

ACK/NAK

### ENQ

When this option is selected, the scanner waits for an ENQ character from the host before transmitting data. If an ENQ is not received within 2 seconds, the scanner issues an error indication and discards the data. The host must transmit an ENQ character at least every 2 seconds to prevent transmission errors.

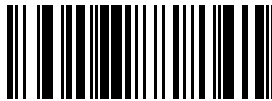

ENQ

### ACK/NAK with ENQ

This combines the two previous options.

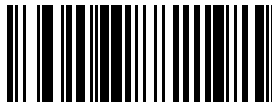

ACK/NAK with ENQ

### XON/XOFF

An XOFF character turns the scanner transmission off until the scanner receives an XON character. There are two situations for XON/XOFF:

- ◆ XOFF is received before the scanner has data to send. When the scanner has data to send, it then waits for an XON character before transmission. The scanner waits up to 2 seconds to receive the XON. If the XON is not received within this time, the scanner issues an error indication and discards the data.

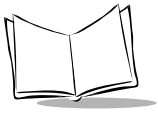

## Software Handshaking (Cont'd)

- ◆ XOFF is received during a transmission. Data transmission then stops after sending the current byte. When the scanner receives an XON character, it sends the rest of the data message. The scanner waits indefinitely for the XON.

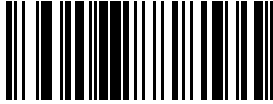

XON/XOFF

## Host Serial Response Time-out

This parameter specifies how long the scanner waits for an ACK, NAK, or CTS before determining that a transmission error has occurred. This only applies when in one of the ACK/NAK Software Handshaking modes, or RTS/CTS Hardware Handshaking option.

The delay period can range from 0.0 to 9.9 seconds in .1-second increments. After scanning the bar code below, scan two numeric bar codes beginning on page 5-93. If you make an error or wish to change your selection, scan **CANCEL** on page 5-95.

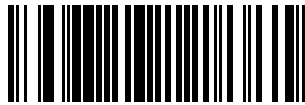

HOST SERIAL RESPONSE TIME-OUT

## RTS Line State

This parameter is used to set the idle state of the Serial Host RTS line. Scan a bar code below to select **LOW RTS** or **HIGH RTS** line state.

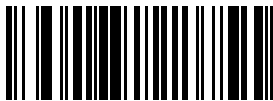

HOST: LOW RTS

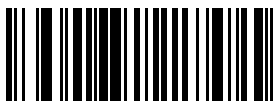

HOST: HIGH RTS

## ***Stop Bit Select***

The stop bit(s) at the end of each transmitted character marks the end of transmission of one character and prepares the receiving device for the next character in the serial data stream. The number of stop bits selected (one or two) depends on the number the receiving terminal is programmed to accommodate. Set the number of stop bits to match host device requirements.

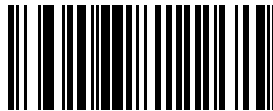

1 STOP BIT



2 STOP BITS

## ***ASCII Format***

This parameter allows the scanner to interface with devices requiring a 7-bit or 8-bit ASCII protocol.

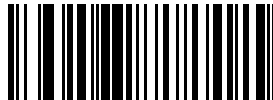

7-BIT

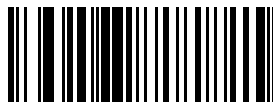

8-BIT

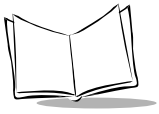

## Beep on <BEL>

When this parameter is enabled, the scanner issues a beep when a <BEL> character is detected on the RS-232C serial line. <BEL> is issued to gain a user's attention to indicate an illegal entry or other important event.



BEEP ON <BEL> CHARACTER  
(ENABLE)

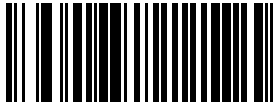

DO NOT BEEP ON <BEL> CHARACTER  
(DISABLE)

## Intercharacter Delay

Select the intercharacter delay option matching host requirements. The intercharacter delay gives the host system time to service its receiver and perform other tasks between characters. The delay period can range from no delay to 99 msec in 1-msec increments. After scanning the bar code below, scan two bar codes beginning on page 5-93 to set the desired time-out. If you make an error or wish to change your selection, scan **CANCEL** on page [5-95](#).

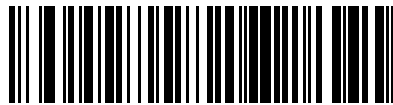

IIINTERCHARACTER DELAY

## Numeric Bar Codes

---

For parameters requiring specific numeric values, scan the appropriately numbered bar code(s).

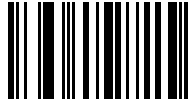

0

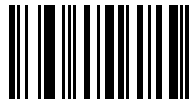

1

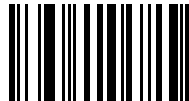

2



3

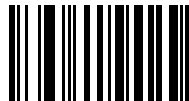

4

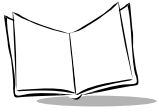

## Numeric Bar Codes (Cont'd)

---



5

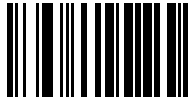

6

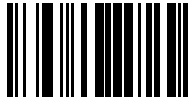

7



8

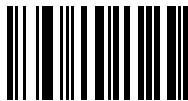

9

## Cancel

---

If you make an error or wish to change your selection, scan the bar code below.



CANCEL

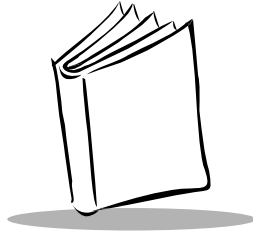

## *Appendix A*

# *Programming Reference*

### **UCC/EAN-128**

---

UCC/EAN-128 is a convention for printing data fields with standard Code 128 bar code symbols. UCC/EAN-128 symbols are distinguished by a leading FNC 1 character as the first or second character in the symbol. Other FNC 1 characters are used to delineate fields.

When EAN-128 symbols are read, they are transmitted after special formatting strips off the leading FNC 1 character and replaces other FNC 1 characters with the ASCII 29 GS control character.

When AIM symbology identifiers are transmitted, the modifier character indicates the position of the leading FNC 1 character according to AIM guidelines. For example, **jc1** indicates a UCC/EAN-128 symbol with a leading FNC1 character.

Standard Code 128 bar codes which do not have a leading FNC 1 may still be used but are not encoded according to the EAN-128 convention. Standard Code 128 and UCC/EAN-128 may be mixed in an application. The LS 400Xi autodiscriminates between these symbols, and can enable or disable one or both code types via bar code menus. [Table A-1](#) indicates the behavior of the LS 400Xi in each of the four possible parameter settings.

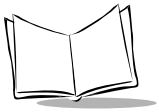

**Table A-1. Reading Standard Code128 & UCC/EAN 128**

<b>Standard Code 128</b>	<b>UCC/EAN-128</b>	<b>Effect and Example</b>
Disable	Disable	No Code 128 symbols can be read.
Disable	Enable	Read only symbols with leading FNC 1. Examples: $FNC1ABCD^{FNC1}E$ are read as $ABCD^{29}E$ $A^{FNC1}BCD^{FNC1}E$ are read as $ABCD^{29}E$ $FNC1FNC1ABCD^{FNC1}E$ are read as $ABCD^{29}E$ $ABCD^{FNC1}E$ cannot be read $ABCDE$ cannot be read
Enable	Disable	Read only symbols without leading FNC 1. Examples: $FNC1ABCD^{FNC1}E$ cannot be read $A^{FNC1}BCD^{FNC1}E$ cannot be read $FNC1FNC1ABCD^{FNC1}E$ cannot be read $ABCD^{FNC1}E$ is read as $ABCD^{29}E$ $ABCDE$ is read as $ABCDE$
Enable	Enable	Read both types of symbols. Examples: $FNC1ABCD^{FNC1}E$ are read as $ABCD^{29}E$ $A^{FNC1}BCD^{FNC1}E$ are read as $ABCD^{29}E$ $FNC1FNC1ABCD^{FNC1}E$ are read as $ABCD^{29}E$ $ABCD^{FNC1}E$ is read as $ABCD^{29}E$ $ABCDE$ is read as $ABCDE$

## AIM Code Identifiers

---

Each AIM Code Identifier contains the three-character string **jcm** where:

- j** = Flag Character (ASCII 93)
- c** = Code Character (see [Table A-2](#))
- m** = Modifier Character (see [Table A-3](#))

**Table A-2. Code Characters**

<b>Code Character</b>	<b>Code Type</b>
A	Code 39
C	Code 128
E	UPC/EAN
F	Codabar
G	Code 93
H	Code 11
I	Interleaved 2 of 5
L	PDF417
M	MSI Plessey
S	D2 of 5, IATA 2 of 5
X	Code 39 Trioptic
X	Bookland EAN
X	Coupon Code

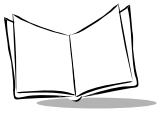

The modifier character is the sum of the applicable option values based on [Table A-3](#).

**Table A-3. Modifier Characters**

Code Type	Option Value	Option
<b>Code 39</b>	0	No check character or Full ASCII processing.
	1	Reader has checked one check character.
	3	Reader has checked and stripped check character.
	4	Reader has performed Full ASCII character conversion.
	5	Reader has performed Full ASCII character conversion and checked one check character.
	7	Reader has performed Full ASCII character conversion and checked and stripped check character.
	Example: A Full ASCII bar code with check character W, <b>A+I+MI+DW</b> , is transmitted as <b>JA7</b> AimId where 7 = (3+4).	
<b>Trioptic Code 39</b>	0	No option specified at this time. Always transmit 0.
	Example: A Trioptic bar code 412356 is transmitted as <b>JX0</b> 412356	
<b>Code 128</b>	0	Standard data packet, no Function code 1 in first symbol position.
	1	Function code 1 in first symbol character position.
	2	Function code 1 in second symbol character position.
	Example: A Code (EAN) 128 bar code with Function 1 character in the first position, <b>FNC1</b> Aim Id is transmitted as <b>JC1</b> AimId	
<b>I 2 of 5</b>	0	No check digit processing.
	1	Reader has validated check digit.
	3	Reader has validated and stripped check digit.
	Example: An I 2 of 5 bar code without check digit, 4123, is transmitted as <b>JIO</b> 4123	
<b>Codabar</b>	0	No check digit processing.
	1	Reader has checked check digit.
	3	Reader has stripped check digit before transmission.
	Example: A Codabar bar code without check digit, 4123, is transmitted as <b>FO</b> 4123	

Table A-3. Modifier Characters (Cont'd)

Code Type	Option Value	Option
<b>Code 93</b>		
	0	No options specified at this time. Always transmit 0.
		Example: A Code 93 bar code 012345678905 is transmitted as <b>JG0012345678905</b>
<b>MSI Plessey</b>	0	Single check digit checked.
	1	Two check digits checked.
	2	Single check digit verified and stripped before transmission.
	3	Two check digits verified and stripped before transmission.
		Example: An MSI Plessey bar code 4123, with a single check digit checked, is transmitted as <b>JM04123</b>
<b>D 2 of 5</b>	0	No options specified at this time. Always transmit 0.
		Example: A D 2 of 5 bar code 4123, is transmitted as <b>JS04123</b>
<b>UPC/EAN</b>	0	Standard packet in full EAN country code format, which is 13 digits for UPC-A and UPC-E (not including supplemental data).
	1	Two-digit supplement data only.
	2	Five-digit supplement data only.
	4	EAN-8 data packet.
		Example: A UPC-A bar code 012345678905 is transmitted as <b>JE00012345678905</b>
<b>Bookland EAN</b>	0	No options specified at this time. Always transmit 0.
		Example: A Bookland EAN bar code 123456789X is transmitted as <b>JX0123456789X</b>

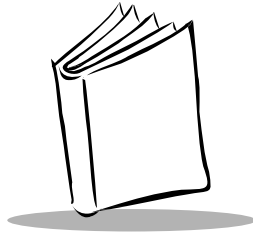

## Index

### A

accessories .....	4-1
optional .....	4-1
required .....	4-1
aiming .....	3-2
hold at an angle .....	3-2
scan the entire symbol .....	3-2

### B

bar codes	
beep after good decode .....	5-16
beeper tone .....	5-12
bi-directional redundancy .....	5-21
codabar .....	5-64–5-68
CLSI editing .....	5-67
lengths .....	5-65
NOTIS editing .....	5-68
code 128 .....	5-38
UCC/EAN-128 .....	5-39
code 39 .....	5-40–5-51
buffering .....	5-49
check digit verification .....	5-46
full ASCII .....	5-48
lengths .....	5-44
transmit check digit .....	5-47
code 93 .....	5-52
lengths .....	5-53, 5-54
data options .....	5-76–5-81
pause duration .....	5-78
prefix/suffix values .....	5-79
scan data xmission format .....	5-80
transmit code ID character .....	5-76
discrete 2 of 5 .....	5-61

lengths .....	5-62, 5-63
host types .....	5-8
interleaved 2 of 5 .....	5-55–5-60
check digit verification .....	5-58
convert to EAN-13 .....	5-60
lengths .....	5-56, 5-57
transmit check digit .....	5-59
laser on time .....	5-14
linear code type security level .....	5-19
MSI plessey .....	5-69–5-74
check digits .....	5-72
lengths .....	5-70
transmit check digit .....	5-73
numeric bar codes .....	5-93
power mode .....	5-15
RS-232C parameters .....	5-82–5-92
ASCII format .....	5-91
baud rate .....	5-82
beep on bel .....	5-92
check receive errors .....	5-85
hardware handshaking .....	5-86
host serial response time-out .....	5-90
intercharacter delay .....	5-92
parity .....	5-84, 5-85
RTS line state .....	5-90
software handshaking .....	5-88
stop bit select .....	5-91
set defaults .....	5-7
transmit no read message .....	5-17
UPC/EAN .....	5-22–5-37
bookland EAN .....	5-24
convert UPC-E to UPC-A .....	5-31, 5-32
coupon code .....	5-37
EAN zero extend .....	5-33

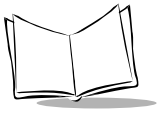

EAN-8/EAN-13 .....	5-23
security level .....	5-35
UPC-A preamble .....	5-28
UPC-E preamble .....	5-29
UPC-E/UPC-A .....	5-22

battery box operation .....	2-4
beeper indications .....	4-7
beeper volume .....	5-13
bullets .....	i

<b>C</b>	
cable .....	2-1
installing .....	2-1
switching .....	2-3
changing the battery .....	2-4
connecting to a host .....	2-5
IBM 468x/469x .....	2-8
RS-232C .....	2-5
conventions	
notational .....	i

<b>D</b>	
dead zone .....	3-2
default table .....	5-2

<b>I</b>	
indications, beeper .....	4-7
information	
service .....	i

<b>M</b>	
maintenance .....	4-1
maximum tilt angles .....	3-2

<b>N</b>	
notational conventions .....	i

<b>P</b>	
parameters, operational .....	5-1
pin outs .....	4-6
power options .....	2-3

<b>R</b>	
recharging a nickel-cadmium battery .....	2-4
related publications .....	i

<b>S</b>	
scan the entire symbol .....	3-2
scanning made easy .....	1-1
service information .....	i
set up .....	2-1
specifications, technical .....	4-2
specular reflection .....	3-2
Symbol Support Center .....	ii

<b>T</b>	
technical specifications .....	4-2
ambient light immunity .....	4-3
beeper operation .....	4-2
coil cable length .....	4-3
decode capability .....	4-2
decode depth of field .....	4-2
dimensions .....	4-3
durability .....	4-3
humidity .....	4-3
laser classification .....	4-3
pitch .....	4-2
power requirements .....	4-2
print contrast minimum .....	4-2
roll tolerance .....	4-2
scan repetition rate .....	4-2
temperature	
operating .....	4-3
storage .....	4-3
yaw .....	4-2

<b>U</b>	
unpacking .....	2-1

# Tell Us What You Think...

We'd like to know what you think about this Manual. Please take a moment to fill out this questionnaire and fax this form to: (516) 738-3318, or mail to:

Symbol Technologies, Inc.  
One Symbol Plaza M/S B-4  
Holtsville, NY 11742-1300  
Attn: Technical Publications Manager

**IMPORTANT:** If you need product support, please call the appropriate customer support number provided. Unfortunately, we cannot provide customer support at the fax number above.

---

User's Manual Title: \_\_\_\_\_  
(please include revision level)

How familiar were you with this product before using this manual?

Very familiar     Slightly familiar     Not at all familiar

Did this manual meet your needs? If not, please explain. \_\_\_\_\_

\_\_\_\_\_

What topics need to be added to the index, if applicable? \_\_\_\_\_

\_\_\_\_\_

What topics do you feel need to be better discussed? Please be specific.

\_\_\_\_\_

What can we do to further improve our manuals? \_\_\_\_\_

\_\_\_\_\_

\_\_\_\_\_

Thank you for your input—We value your comments.